

**XTOOL**

# User Manual

## H6 Elite Smart Diagnostics System



Shenzhen Xtooltech Intelligent Co., LTD

Please read this user manual carefully before using the H6 ELITE Smart Diagnostics System. When reading the manual, please pay attention to the words “Note” or “Caution”, and read them carefully for appropriate operation.

## **TRADEMARKS**

**XTOOL** is a registered trademark of Shenzhen Xtooltech Intelligent CO., LTD. In countries where the trademarks, service marks, domain names, logos and the name of the company are not registered, Xtool claims that it still reserves the ownership of the unregistered trademarks, service marks, domain names, logos and the company name. All other marks for the other products and the company’s name mentioned in the manual still belong to the original registered company. You may not use the trademarks, service marks, domain names, logo and company name of Xtool or other companies mentioned without written permission from the trademark holder. Xtool reserves the right to the final interpretation of this manual content.

## **COPYRIGHT**

Without the written consent of Shenzhen Xtooltech Intelligent Co., Ltd., any company or individual shall not copy or backup this operation manual in any form (electronic, mechanical, photocopying, recording or other forms).

## **DECLARATION**

This manual is designed for the usage of the H6 ELITE Smart Diagnostics System and provides operating instructions and product descriptions for users of the H6 ELITE Smart Diagnostic system.

No part of this manual can be reproduced, stored in a retrieval system or transmitted, in any form or by any means (electronic, mechanical, photocopying, recording, or otherwise), without the prior written permission of Xtool.

Use the device only as described in this manual. Xtool is not responsible for any consequences of violating the laws and regulations caused by using the product or its data information

Xtool shall not be liable for any incidental or consequential damages or for any economic consequential damages arising from the accidents of individual users and the third parties, misuse or abuse of the device, unauthorized change or repair of the device, or the failure made by the user not to use the product according to the manual.

The configuration, function, appearance and UI of this product involved in the user manual will continue to be optimized, and the manual may not be updated in time. Please refer to the actual product if there is any difference. The final interpretation right belongs to Shenzhen Xtooltech Intelligent Co., Ltd.

## **OPERATION INSTRUCTIONS**

For safe operation, please follow the instructions below:

- Keep the device away from heat or fumes when you use it.
- If the vehicle battery contains acid, please keep your hands and skin or fire sources away from the battery during testing.
- The exhaust gas of the vehicle contains harmful chemicals, please ensure adequate ventilation.
- Do not touch the cooling system components or exhaust manifolds when the engine is running due to the high temperatures reached.
- Make sure the car is securely parked, Neutral is selected or the selector is at P or N position to prevent the vehicle from moving when the engine starts.
- Do not switch off the power or unplug the connectors during testing, otherwise, you may damage the ECU and/or the Diagnostic Tablet.

## **CAUTIONS!**

- Avoid shaking or dismantling the unit as it may damage the internal components.
- Do not use hard or sharp objects to touch the LCD screen;
- Do not use excessive force;
- Do not expose the screen to strong sunlight for a long period.
- Please keep it away from water, moisture, high temperature or very low temperature.

- If necessary, calibrate the screen before testing to ensure the accuracy of LCD performance.
- Keep the main unit away from strong magnetic fields.

## **AFTERSALES-SERVICES**



E-Mail: [supporting@xtooltech.com](mailto:supporting@xtooltech.com)



Tel: +86 755 21670995 or +86 755 86267858 (China)



Official Website: [www.xtooltech.co](http://www.xtooltech.co)

NOTE: When seeking technical support, please provide:

- S/N of your device
- VIN of your vehicle
- Software version

This will help us quickly locate your problem

# Content

<b>TRADEMARKS .....</b>	<b>I</b>
<b>COPYRIGHT .....</b>	<b>I</b>
<b>DECLARATION .....</b>	<b>I</b>
<b>OPERATION INSTRUCTIONS .....</b>	<b>II</b>
<b>CAUTIONS! .....</b>	<b>II</b>
<b>AFTERSALES-SERVICES.....</b>	<b>III</b>
<b>1. GENERAL INTRODUCTION.....</b>	<b>4</b>
1.1. Car DIAGNOSTICS Tablet.....	4
<i>Front View of Tablet .....</i>	<i>5</i>
<i>Back View of Tablet.....</i>	<i>6</i>
<i>Host Ports.....</i>	<i>7</i>
1.2. Specifications .....	7
1.3. Packing List.....	8
<b>2. GETTING STARTED .....</b>	<b>9</b>
2.1. Activation.....	9
2.2. Main Interface.....	11
<i>Operation system .....</i>	<i>11</i>
<i>Diagnosis system entrance.....</i>	<i>13</i>
<i>Function Buttons.....</i>	<i>14</i>
<i>Navigation Buttons .....</i>	<i>15</i>
<i>Notification Bar.....</i>	<i>16</i>
<b>3. UPDATE &amp;DELETE SOFTWARE .....</b>	<b>17</b>
3.1. Update Software.....	17

3.2.	Delete Software.....	18
<b>4.</b>	<b>DIAGNOSIS .....</b>	<b>19</b>
4.1.	Vehicle Connection .....	19
4.2.	Diagnosis.....	21
	<i>Vehicle Selection.....</i>	<i>21</i>
	<i>Diagnosis functions.....</i>	<i>25</i>
<b>5.</b>	<b>SPECIAL FUNCTIONS.....</b>	<b>34</b>
5.1	OIL RESET .....	34
5.2	EPB.....	36
5.3	SAS.....	38
5.4	DPF.....	41
5.5	BMS RESET .....	45
5.6	THROTTLE .....	47
5.7	INJECTOR CODING.....	49
5.8	GEARBOX MATCH .....	52
5.9	GEAR LEARNING .....	52
<b>6.</b>	<b>REPORT .....</b>	<b>54</b>
6.1.	Report .....	55
6.2.	Replay .....	57
6.3.	File Manager .....	57
<b>7.</b>	<b>SETTINGS .....</b>	<b>58</b>
7.1.	Language .....	58
7.2.	Units .....	59
7.3.	My Workshop Info .....	60
7.4.	Firmware Information .....	60
7.5.	About.....	61
<b>8.</b>	<b>FACTORY RESET .....</b>	<b>62</b>

<b>9. REMOTE ASSISTANCE.....</b>	<b>65</b>
<b>10. FAQ.....</b>	<b>67</b>
Q1: Failed to generate diagnosis report.....	67
Q2: How to print diagnosis report .....	68
Q3: Failed to extract files .....	69
Q4: Mailbox supported.....	69
Q5: How to make an appointment for remote support .....	69
Q6: How to generate and upload diagnostic log files .....	69
Q7: How to switch languages .....	69
Q8: Failed to diagnose vehicle.....	70
Q9: Failed to activate or register.....	70
Q10: Failed to turn on when charging .....	71
Q11: Failed to open the diagnosis app .....	71
Q12: Failed to enter Vehicle menu .....	71
<b>9. WARRANTY &amp; SERVICES .....</b>	<b>72</b>
<b>SHENZHEN XTOOLTECH INTELLIGENT CO., LTD.....</b>	<b>74</b>

# 1. GENERAL INTRODUCTION

The H6 ELITE smart diagnostic system is an advanced scanning tool based on the Android operating system. It supports multi-language switching and is suitable for different countries and regions. The advantage of this OBD II scanner is not only its comprehensive functions, including complete system diagnosis, but all OBD II functions, various reset functions can also achieve a faster and more accurate diagnosis.

The H6 Elite Smart Diagnostics System mainly includes:

- Car diagnostics tablet
- Main test cable & OBD2 adapter
- Power adapter
- OBD1 connectors

\*Before performing the diagnosis program, please make sure that the VCI box is successfully connected to your vehicle, and connect the VCI box with Bluetooth on the tablet.

\*\*Some old cars with non-OBD2 standard protocol need to be connected with our VCI box through OBD-1 connectors. Using the wrong connector may cause your car to be unrecognized by the diagnostic tool. Please confirm the OBD connector specifications configured on your car before connecting.

## 1.1. TABLET

The main unit of the H6 ELITE is the tablet, which has a built-in VCI module, which can be directly connected to the tablet and the car with the main test cable, without the need to connect to an external VCI box via Bluetooth.



## FRONT VIEW OF TABLET



*Figure 1-1 Sample of Tablet Front View*

The front of the main unit is a touchable display screen, you can use your fingers to operate the screen to complete the car diagnosis.

## BACK VIEW OF TABLET



*Figure 1-2 Sample of Tablet Back View*

- ① **Camera:** 8-megapixel camera, for taking pictures.
- ② **Tablet Holder:** Used to support the tablet, flexible adjustment of the tablet height as needed.
- ③ **Nameplate:** Display the basic information about the tablet such as product name and model etc.
- ④ **Loudspeaker:** It supports playing external sounds.

## HOST PORTS

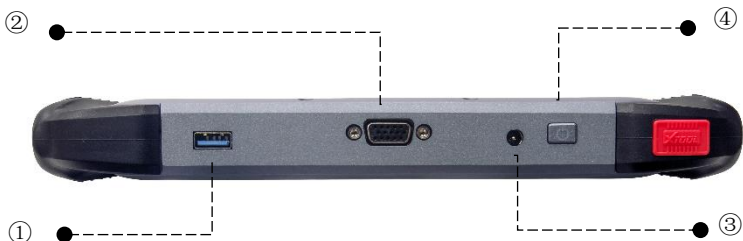

Fig 1-3 Sample of Tablet Host Ports

- ① **USB 3.0 port:** Data transfer port. (*Please do not use other non-xtool UBS cables with this port!*)
- ② **VGA port:** A reserved interface can be used for charging.
- ③ **DC charging port:** Charging port, connected to the charger can be charged.
- ④ **Power button:** Long press to turn on/off, short press to rest/brighten the screen.

## 1.1. SPECIFICATIONS

Table 1-1 Specification

Item	Description
OS	Android
Processor	Quad-core processor 1.8GHz
Ram	2G
Rom	64G
Display	8-inch capacitive, 1024×768 resolution

<b>Connectivity</b>	<ul style="list-style-type: none"> <li>● USB</li> <li>● Wi-Fi</li> </ul>
<b>Camera</b>	8-megapixel autofocus rear camera with flash
<b>Sensor</b>	Gravity sensor
<b>Audio Input/ Audio Output</b>	Microphone/ Loudspeaker
<b>Ports</b>	<ul style="list-style-type: none"> <li>● USB3.0</li> <li>● DC charging port</li> <li>● VGA port</li> </ul>
<b>Battery</b>	10000mAh 3.7V lithium polymer battery
<b>Input Voltage</b>	12V DC
<b>Operating Temperature</b>	-10~50°C
<b>Relative Humidity</b>	< 90%
<b>Dimensions</b>	274.0×175.0×33.8 mm

### 1.3. PACKING LIST

Table 1-2 Packing List

Category	No.	Name	QTY
<b>Main Units</b>	1	Tablet	1
	2	VCI Box	1
	3	USB 3.0 Cable	1
<b>Adaptor</b>	1	DC12V(AC100~240V) 3A	1
	2	US power cable	1
	3	EU power cable	1

<b>Accessories</b>	1	Tool kit	1
	2	Certificate of Quality	1
	3	Packing List	1
	4	User Manual	1
	5	Carton	1

## 2. GETTING STARTED

### 2.1. ACTIVATION

After first-time users press and hold the power button to turn on the system, the system will automatically enter the guide process and request to select the language for the operating system.



*Figure 2-1 Sample of Selection Languages*

After setting the system language, you will enter the activation page, as shown in the figure below. You can also click the "Trial" button in the upper right corner to try it out before activation.

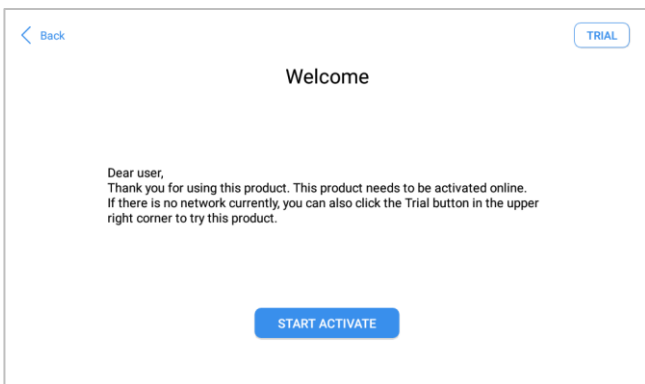

*Figure 2-2 Sample of Activation (Screen 1)*

Click Start Activate to enter the activation page, as shown below:

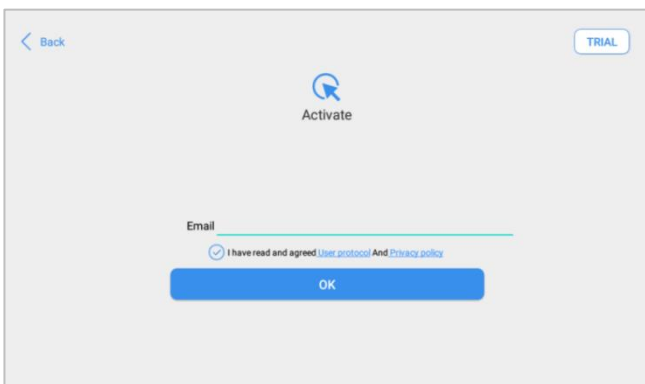

*Figure 2-3 Sample of Activation (Screen 2)*

A pop-up window showing Activation Success indicates that you have completed the first boot setup, click OK to enter the diagnostic system and start using the device.

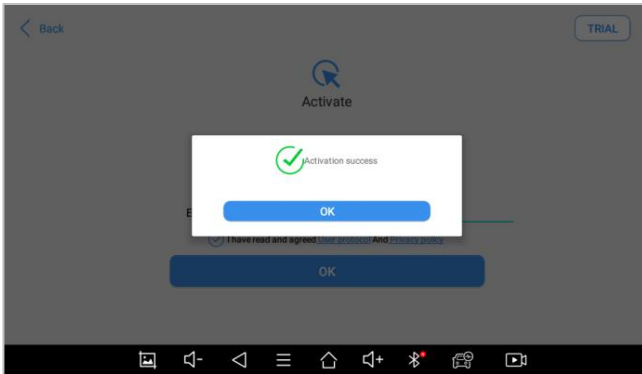

*Figure 2-4 Sample of Activation (Screen 3)*

## **2.2. MAIN INTERFACE**

### **OPERATION SYSTEM**







As shown in the figure below, this interface is the main page of the operating system of the device. You can also return to this interface at any time by clicking the home button on the bottom navigation bar.



*Figure 2-5 Sample of OS Main page*

The icons on the right, from top to bottom, are browser, photo album, application square, file manager, and system settings, as shown below:

Table 2-1

Items	Descriptions
	Browser
	Album
	Application Square
	File Explorer
	Settings for Android System
	H6 ELITE Smart Diagnostics System

- a) **Browser:** Click on the browser icon to enter the browser to view the official website of Xtool or search for other information.
- b) **Gallery:** Click the **Gallery** icon to enter the album to quickly view the pictures or screenshots stored on the device. You can select the picture you need, click the share button on the upper right, and send the picture to your mobile phone or PC via Bluetooth or USB connection
- c) **Application Square:** You can check all Apps installed here.
- d) **ES File Explorer:** You can manage APP, music, files, pictures, etc. in the device in this function, and you can also use Local/Home/Cleaner to clean up files.



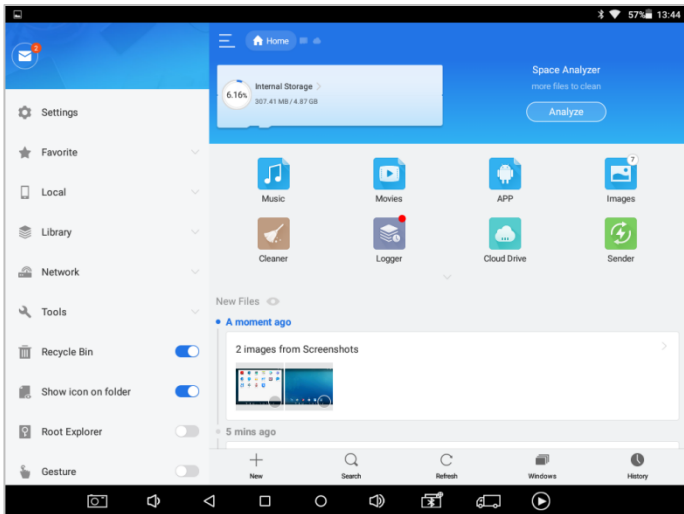

Figure 2-6 Sample of ES File Explorer

- e) **H6 Elite Smart Diagnostics System:** The App allows you to diagnose your vehicle and offers a range of specialist maintenance services.

## DIAGNOSIS SYSTEM ENTRANCE

Once activated, you will automatically enter the diagnostic system with the following main screen. Tap on the diagnosis application button on the menu, the main interface will be shown as below:





Figure 2-7 Sample of APP Main Page





The main interface is mainly composed of **Function Buttons** and **Navigation Buttons**. The touch screen navigation is menu-driven, and you can quickly access functions by clicking on the option title and answering the dialogue window. A detailed description of the menu structure can be found in the next section **Function Buttons**.

## FUNCTION BUTTONS

The following table briefly describes each function button

Table 2-2







Item	Description
	Quickly access the vehicle system to identify the vehicle's VIN code
	Enter to select a vehicle
	Includes special functions for car diagnosis



	You can view the vehicle diagnostic report
	In case of failure, you can control the diagnostic equipment remotely
	Users can upgrade the upgradeable software with one click
	Users can set the language, unit, and workshop information here
	Users can view extended functions, such as an endoscope

## NAVIGATION BUTTONS

Instructions for operating the navigation bar buttons at the bottom of the screen, as described in the table below:

*Table 2-3*

Items	Descriptions
	Press for screenshot
	Decrease volume
	Back to the previous interface
	Shows recently used applications
	Back to the main interface of the Android system
	Increase volume
	Showing the Bluetooth states

	Click this button to return to the diagnostic vehicle interface
	Press for screen recording

## NOTIFICATION BAR

Slide down to open the notification bar. Users can adjust the brightness of the screen when they need it, and you can also connect Wi-Fi and so on.

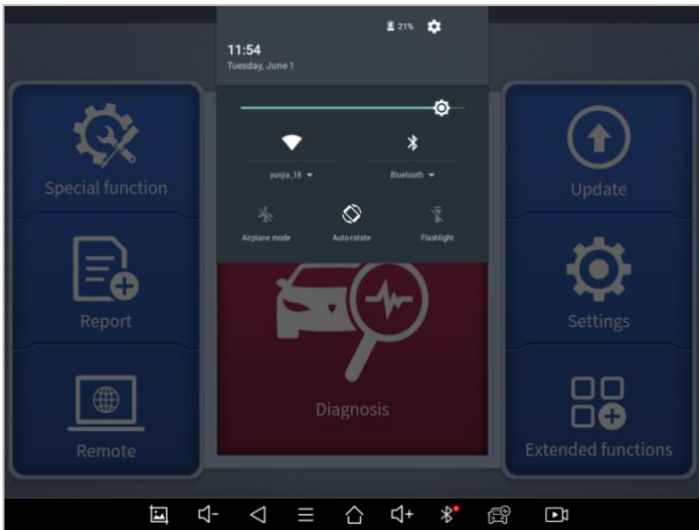
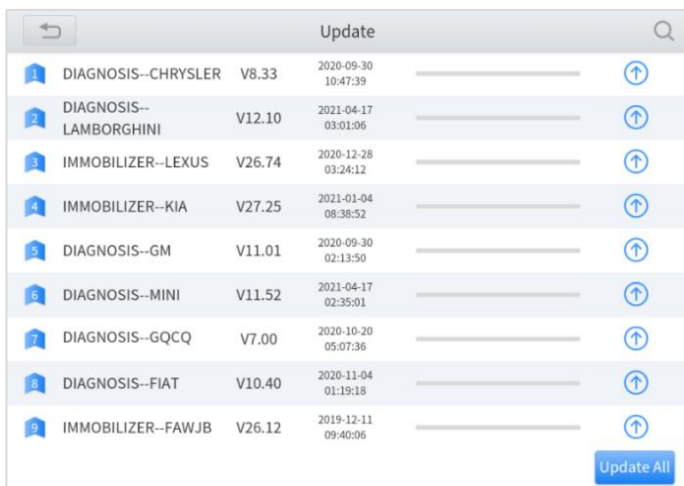

*Figure 2-8 Sample of NOTIFICATION BAR*

## 3. UPDATE & DELETE SOFTWARE

### 3.1. UPDATE SOFTWARE

After activating the device, please update the software in "Update" first. To access the update application, open the diagnosis application and click UPDATE, shown below:



	Update				
1	DIAGNOSIS--CHRYSLER	V8.33	2020-09-30 10:47:39	—————	↑
2	DIAGNOSIS-- LAMBORGHINI	V12.10	2021-04-17 03:01:06	—————	↑
3	IMMOBILIZER--LEXUS	V26.74	2020-12-28 03:24:12	—————	↑
4	IMMOBILIZER--KIA	V27.25	2021-01-04 08:38:52	—————	↑
5	DIAGNOSIS--GM	V11.01	2020-09-30 02:13:50	—————	↑
6	DIAGNOSIS--MINI	V11.52	2021-04-17 02:35:01	—————	↑
7	DIAGNOSIS--GQCQ	V7.00	2020-10-20 05:07:36	—————	↑
8	DIAGNOSIS--FIAT	V10.40	2020-11-04 01:19:18	—————	↑
9	IMMOBILIZER--FAWJB	V26.12	2019-12-11 09:40:06	—————	↑

Update All

Figure 3-1 Sample of Update List

- Click the  in the upper right corner to search for model software by keywords
- Click the up arrow on the right to download the specified package
- Click **UPDATES ALL** at the bottom right to download all packages

**i** After activating the device for the first time, please check the update.

**i** Software updates in English and the local languages are generally supported, but to save storage space, we recommend that you better update in one language.

## 3.2. DELETE SOFTWARE

Long-press the unwanted software until it has been selected, then click the **Delete** button shown on the upper part of the screen. And you can select and delete multiple software at once.

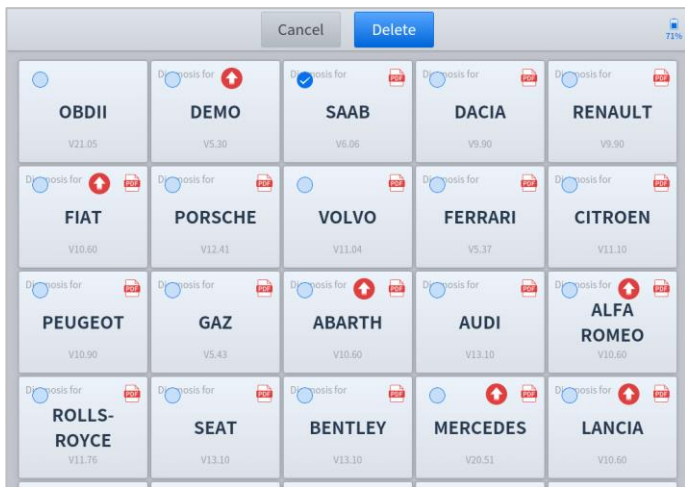

*Figure 3-2 Sample of How to Delete Vehicle Software*

\*\* When the device prompts that the memory is insufficient, you can delete the models that are not frequently used to release the memory.

## 4. DIAGNOSIS

The diagnostic application can read ECU information, read and clear DTC and check live data and freeze frames. The diagnosis application can access the electronic control unit (ECU) of various vehicle control systems, including the engine, transmission, anti-lock braking system (ABS), airbag system (SRS), and perform kinds of actuation tests.

### 4.1. VEHICLE CONNECTION

The diagnosis operation needs to connect the H6 Elite Smart Diagnostics System to a vehicle first so that the tablet can establish correct vehicle communication. Please perform the following steps:

Since the display tablet and the VCI box are integrated, to communicate with the vehicle, the OBD II -16 connector must be connected to the main test cable, and the vehicle data connector should be inserted into the DLC usually located under the vehicle dashboard. The OBDII-16 adapter should be connected to the vehicle, the main test line should be connected to the OBDII-16 adapter, and the tablet

The connection method is shown in the figure below:

Please perform the following steps:

Turn on the tablet;

Connect cables and tablet in the following order: ①→②→③→④;

Switch on the ignition and tap on the Diagnosis application to test vehicles.

The connection method is shown in the figure below:

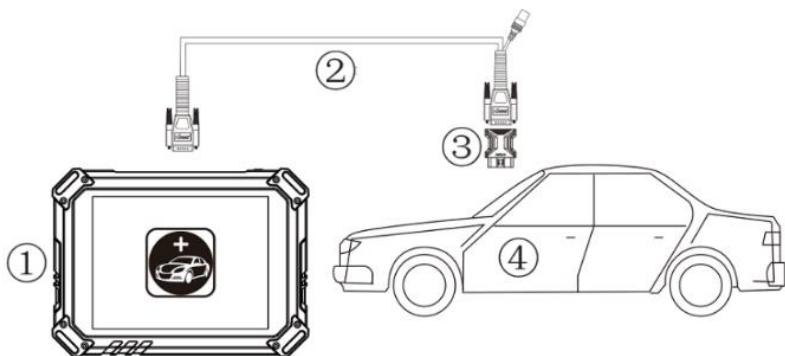

Figure 4-1 Sample of How to Connect Device to Vehicle

- ① Tablet
- ② Main Test Cable
- ③ OBDII-16 Connector
- ④ Vehicle

## ● Precautions for Diagnosis

1. The battery voltage range on the car: +9~+36V DC;

2. When testing some special functions, the operator must operate according to the prompts and meet the test conditions. For some models [special functions], the conditions that need to be met are: engine water temperature 80°C~105°C, turn off headlights and air conditioners, Keep the accelerator pedal in the released position, etc.;

3. As the electronic control systems of different models are more complicated, if you encounter situations where it is impossible to test or a large amount of test data is abnormal, you can search for the ECU of the vehicle and select the menu through the model on the ECU nameplate;



4. If the vehicle type or electronic control system to be tested is not found in the H6 Elite diagnostic function, please upgrade the vehicle diagnostic software to the latest version or consult the technical service department;

5. It is forbidden to use wiring harnesses other than Xtool for connection testing to avoid unnecessary losses;

6. In the communication between the H6 ELITE Smart Diagnostics System and the vehicle, it is forbidden to shut down directly. You should cancel the task before returning to the main interface.

## 4.2. DIAGNOSIS

After the tablet device is properly connected to the vehicle, you could start the vehicle diagnosis.

### VEHICLE SELECTION

The H6 ELITE Smart Diagnosis system supports the following 4 ways to access the vehicle diagnosis system.

- AUTO SCAN
- SCAN CODE
- MANUAL ENTER
- SELECT VEHICLE BY AREA

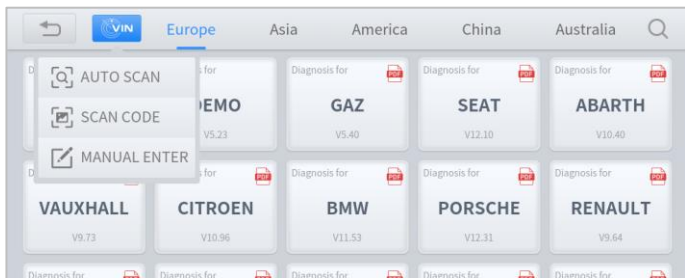

*Fig 4-2 Sample of Vin Identification*

Click the VIN button in the upper left corner, you can choose to enter the vehicle diagnosis through the 2 ways of **AUTO SCAN/MANUAL ENTER**.

- **AUTO SCAN:** It supports automatic reading of vehicle VIN code. You also can tap on the button “AUTO SCAN” on the diagnosis system entrance to use this function. \*Please make sure that the car and the device are well connected before using this function.

⚠ If your model is not recognized, please try the following steps:

- ✓ UPDATE all software, and check whether the APP is updated in [Settings]
  - ✓ Please click Diagnosis on the main menu to enter the model selection menu, manually select the engine system to read the ECU information, and check whether the VIN is written in the engine;
  - ✓ Contact the Xtooltech technical team to provide the VIN code to confirm whether the model supports automatic identification of VIN.
- **MANUAL ENTER:** It supports manual input of car VIN code. When entering the VIN code manually, make sure that the 17 characters entered are correct to avoid reading failure.

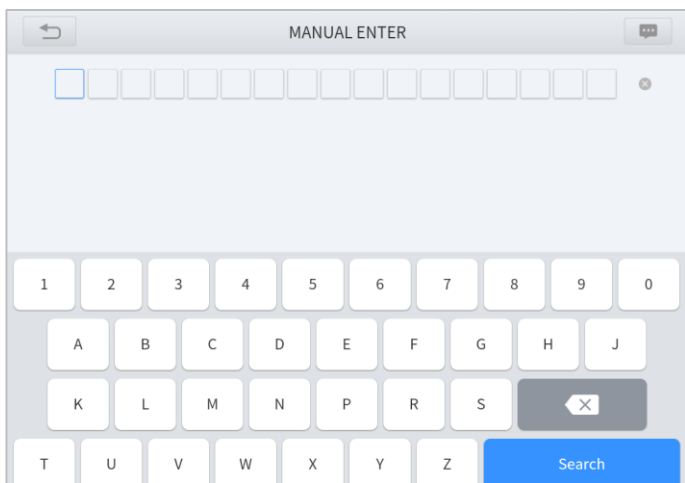

*Fig 4-3 Sample of Manually Inputting Vin*

**NOTE:** This function keeps the history of manually inputting the VIN code, you can directly select the history record below to confirm the vehicle information after the first manually input.

- **SELECT VEHICLE BY AREA:** In addition to the above 3 methods, you can also choose a car brand according to the region. You can select the vehicle model that needs to be diagnosed according to the area, as shown below:

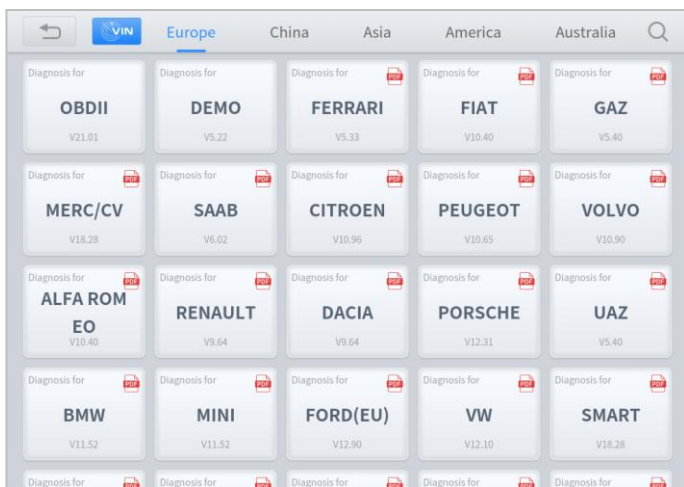

*Figure 4-4 Sample of Vehicle Selection by Ares*

OBd- II supports reading the related fault codes of PCM; DEMO, a demonstration program; Click this button to experience and learn the operation process of the diagnostic function. Some models provide multiple entry methods in the sub-menu, including:

- Automatic Detection
- Manual Selection
- System Selection



*Figure 4-6 Sample of Diagnosis Method Selection*

**Automatic Detection** will automatically identify the vehicle's VIN code, and then read the information of your target diagnostic object. If you choose "**Manual selection**", then you can continue to select the vehicle brand, year, and model of the vehicle in the sub-menu to diagnose the vehicle. Enter "**System Selection**", you can also diagnose the vehicle according to the system according to your needs after selecting the model.

## DIAGNOSIS FUNCTIONS

Diagnostics functions supported by the H6 Elite Smart Diagnostics System are as below:

- **Read ECU Information**
- **Read/Clear Trouble Code**
- **Read Live Data**
- **Actuation Test (Bi-Directional Control)**
- **Freeze Frame**
- **Special functions**

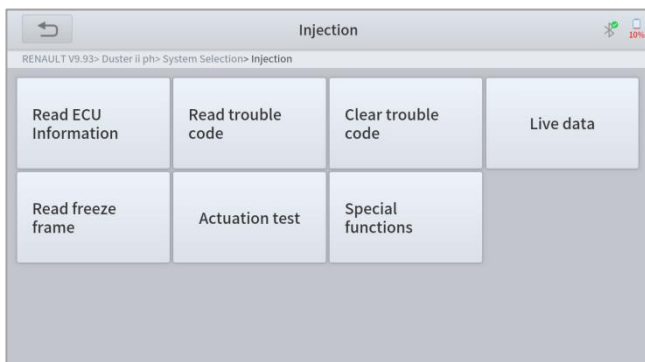

*Figure 4-7 Sample of Diagnosis Functions*

### ■ **Read ECU Information**

This function is to read ECU version information, which is the equivalent of "**System Identification**" or "**System information**" in some electronic control

systems, all mean to read ECU-related software and hardware versions, models and production date of diesel engine, part number, etc. It is convenient for us to make a record in the maintenance process, and it also makes data feedback and management easier.

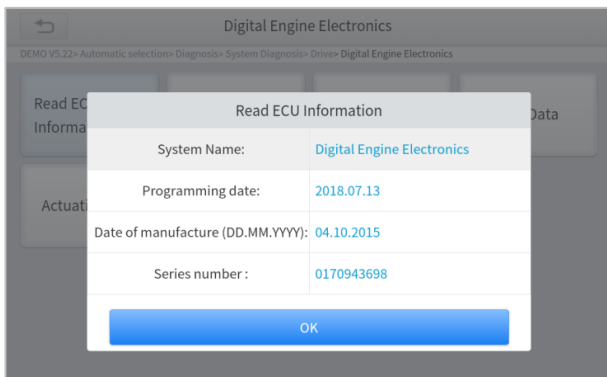

Figure 4-8 Sample of ECU Information

### ■ Read Trouble Code

Read trouble codes stored in ECU.

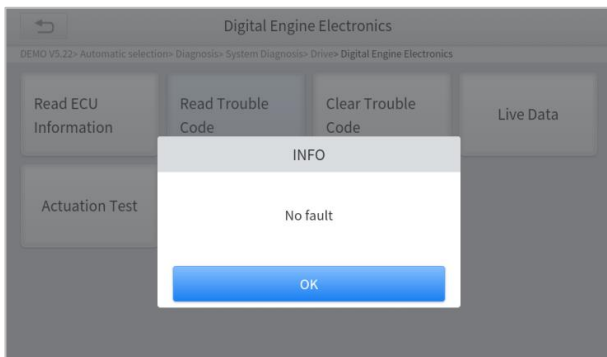
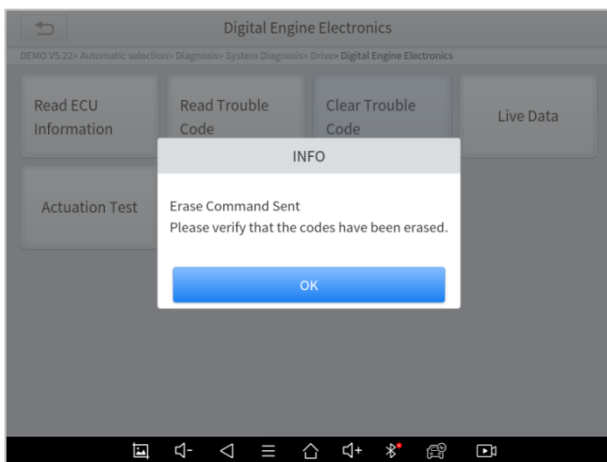

Figure 4-9 Sample of reading DTC

**\*Tip:** In the process of diagnosis, if the device shows **“System is OK”** or **“No Trouble Code”**, it means there is no related trouble code stored in ECU or some troubles are not under the control of ECU, most of these troubles are mechanical system troubles or executive circuit troubles, it is also possible that signal of the sensor may bias within limits, which can be judged in Live Data.

### ■ Clear Trouble Code

It allows clearing current and historical trouble codes memory in ECU, under the premise that all the troubles are eliminated.



*Figure 4-10 Sample of Clear DTC*

The trouble codes can't be erased without eliminating all the troubles, which will cause the diagnostic tool to always read the trouble code because the code will always be saved in ECU. Suggestion: users should better not clear trouble codes, we need to record the trouble details after reading the code, which is provided as a reference for maintenance. After dealing with troubles, there will be no trouble code when we re-read.

### ■ Read Live Data

That is to read the parameters of the running engine, such as oil pressure, temperature, engine speed, fuel oil temperature, coolant temperature, intake air temperature, etc. Based on these parameters, we can judge directly where the problem lies, which helps to narrow the scope of maintenance. For some vehicles, during their actual operation, the problems such as performance characteristics offset, and sensitivity reduction can be judged in live data.

In the process of diagnosis, if the device shows “**System is OK**” or “**No Trouble Code**”, it means there is no related trouble code stored in ECU or some troubles are not under the control of ECU, most of these troubles are mechanical system troubles or executive circuit troubles, it is also possible that signal of the sensor may bias within limits, which can be judged in Live Data.

Name	Value	Unit
<input type="checkbox"/> Engine speed	6171.75	1/min
<input type="checkbox"/> Coolant temperature	-48.00	degree C
<input type="checkbox"/> Engine oil temperature	3020.25	degree C
<input type="checkbox"/> Emissions warning light: Status	off	
<input type="checkbox"/> Emissions warning light: Distance travelled since activation	N/A	km
<input type="checkbox"/> Status, engine warning light	148	
<input type="checkbox"/> Operating time since engine start	6020.00	s
<input type="checkbox"/> Operating hour counter	3756.00	min

Figure 4-11 Sample of PIDs List

- Click the magnifying glass on the top right, you can search for related PIDs based on keywords.



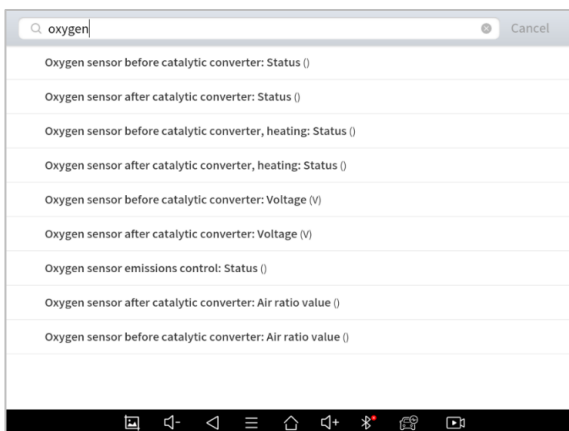

Figure 4-12 Sample of the PIDs List related by Key Words

## ● Custom

Support to show the selected PIDs.

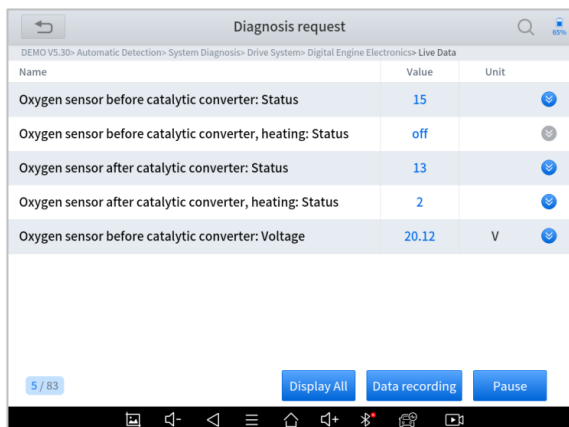

Figure 4-13 Sample of Custom the PIDs

Click Display All, back to the page which displays all PIDs

- **Combine**

Support to select multiple PIDs and click **【Combine】** to make different graphs into one chart. \*Note: When combining the PIDs, the number of them selected at a time should not exceed 5

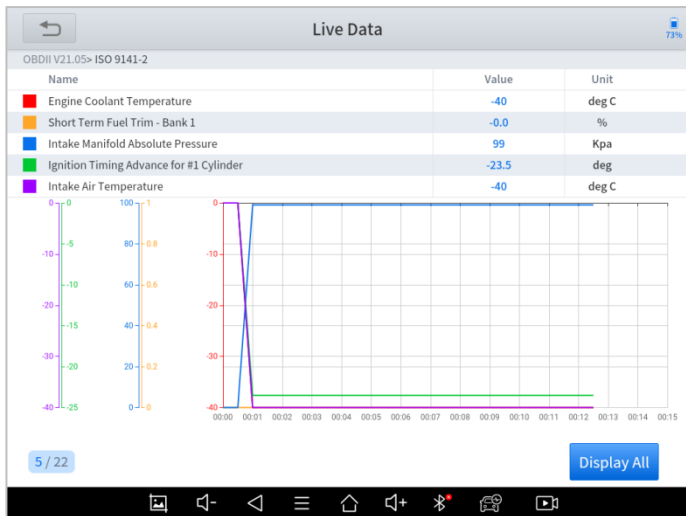

Figure 4-14 Sample of the PIDs Combination

- **Data recording**

Supports recording the current data value in the form of text, you can view the recorded files in **Reports->Data Replay**.

- **Pause**

Click this button to pause the timeline of timeline

- **Freeze Frame**

When the signal of the sensor is abnormal, the ECU will save the data at that moment of failure to form a freeze-frame. It is usually used to analyze the reasons that may lead to car failures.

The living data items supported by vehicles of different brands are not the same, so the freeze frames displayed when diagnosing vehicles of different brands may also be different. Some vehicles may not have the option of a freeze-frame which means that the model does not support this function.

Take **Renault Duster ii ph** as an example, after selecting the system to enter the lower freeze frame menu, the device will list all the fault codes under the system.

Users can click on a fault code, such as **DF1068** to view the freeze frame recorded by the car when the fault code occurs, including context when the fault appeared, and current context and additional data.

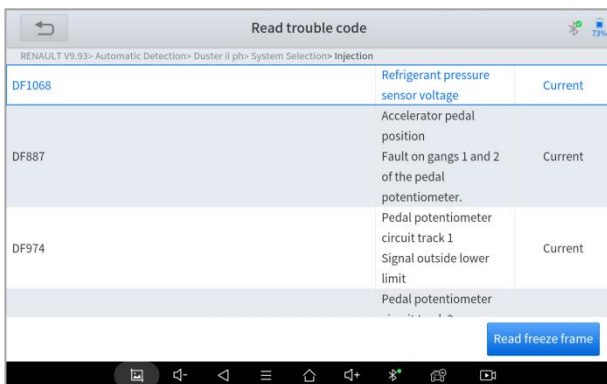

Figure 4-17 Sample of the Freeze frame for Renault Duster ii ph (Screen 1)



Figure 4-18 Sample of the Freeze frame for Renault Duster ii ph (Screen 2)

Context when fault appeared: record the live data when fault appeared to help the user to know the vehicle status. \*Some vehicles don't support this function; users will get a prompt when they click the menu.

Current context: Displays the current live data stream associated with the DTC

NO.	Name	Value	Unit
1	Current context:		
2	Water temperature	-40.0	deg C
3	Computer supply voltage	11.97	V
4	Engine speed	0	rpm
5	Vehicle speed	0.00	km/h
6	Engine torque	0.00	nm
7	Refrigerant pressure	34	bar
8	Refrigerant fluid sensor voltage	-322.68	V

Figure 4-19 Sample of the Freeze frame for Renault Duster ii ph (Screen 3)

Additional data: record other data related to the fault

NO.	Name	Value	Unit
1	Additional data:		
2	Mileage since fault last disappeared		km
3	Mileage since last appearance of fault		km
4	Number of occurrences of fault		
5	Distance when fault first occurred		km
6	Distance travelled with fault present		km

Figure 4-20 Sample of the Freeze frame for Renault Duster ii ph (Screen 4)

## ■ Special functions



Figure 4-21 Sample of the Special Functions for the Injection system of Renault Duster ii ph

Usually, special functions provide various reset or re-learning function menus for most vehicle systems. You can easily and quickly solve some faults through special functions for your car. After some functions are successfully executed, fault codes will be generated, which need to be cleared manually after the car is running for a little while.

And under each system, you can view the special features supported by that system. Different models and systems often have different special functions. Even for the same system of the same model, the years and ECU type may lead to different special functions supported.

## 5. SPECIAL FUNCTIONS

The H6 ELITE Smart Diagnostics System supports the commonly used special reset functions, allowing you to quickly access your vehicle system for various scheduled services, maintenance and reset performance, eliminating the need to reset after resolving common problems. This user manual lists some of the commonly used special reset services for your reference. The special functions interface is shown below:

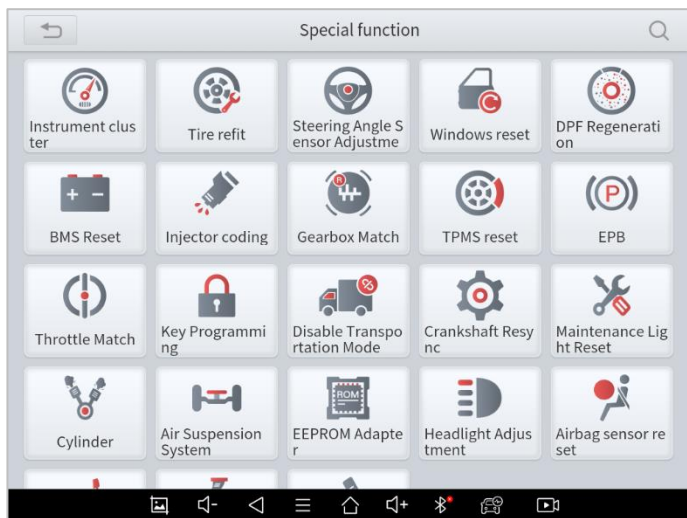

Figure 5-1 Sample of Special Functions

- Due to the limitation of screenshots, the special functions shown in this picture are not complete.
- All special functions supported by H6 ELITE are subject to the actual special functions displayed on the device.

### 5.1 OIL RESET

Reset the Engine Oil Life System, which calculates the optimum oil life change interval based on the vehicle's driving conditions and climate. The oil life reminder must be reset each time the oil is changed so that the system can calculate when the next oil change is required.

This function can be performed in the following cases:

- If the service lamp is on, you must provide service for the car. After service, you need to reset the driving mileage or driving time so that the service lamp turns off and the system enables the new service cycle.
- After changing engine oil or electric appliances that monitor oil life, you need to reset the service lamp.

**The operation guidelines of the Oil Reset function are shown below:**

1. Enter the **Oil Reset** menu and choose relevant models according to the vehicle being tested.
2. Follow the instructions displayed and press **OK** after completing the instructions shown.

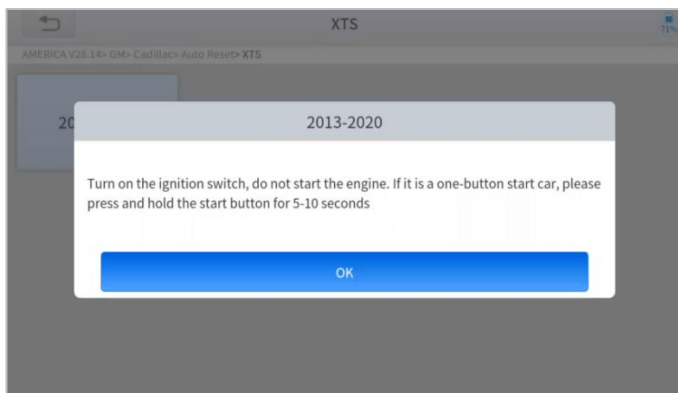

*Figure 5-2 Sample of oil reset function (screen 1)*

3. Enter the Maintenance mileage reset menu.
4. Input reasonable value of mileage and press OK.
5. Message of 'Reset success' displayed when Oil Reset function has successfully performed.

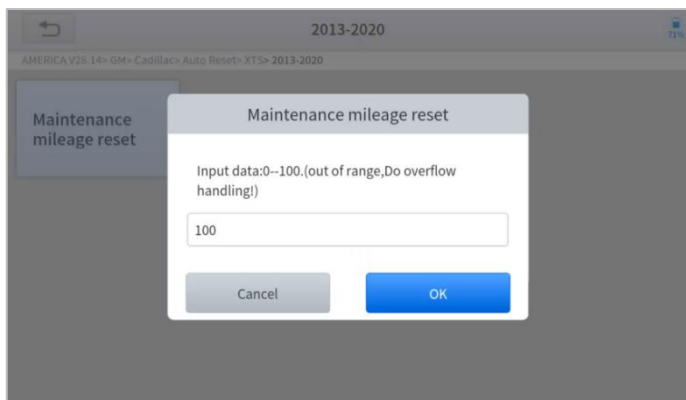

*Figure 5-3 Sample of oil reset function (screen 2)*

## 5.2 EPB

Electronic Parking Brake (EPB) System reset is a popular special function. You can use this function to reset the electronic parking brake system and brake pads, which also supports the brake pad replacement (retraction, release of the brake pump), G-sensor, and body angle calibration. This function has multiple uses and can safely and effectively maintain the electronic brake system. These applications include deactivating and activating brake control systems, assisting in controlling brake fluid, opening and closing brake pads, setting brakes after replacing brake discs or brake pads, etc.

1. If the brake pad wears the brake pad sense line, the brake pad sense line will send a signal to the onboard tablet asking for replacing the brake pad. After replacing the brake pad, you must reset the brake pad. Otherwise, the car alarms.
2. Reset must be performed in the following cases:
  - The brake pad and brake pad wear sensor are replaced.
  - The brake pad indicator lamp is on.
  - The brake pad sensor circuit is short, which is recovered.
  - The servo motor is replaced.

***The operation guidelines of the EPB function are shown below:***



1. Enter the **EPB** menu and choose relevant models according to the vehicle being tested.
2. Follow the instructions displayed and press **YES** after completing the instructions shown.

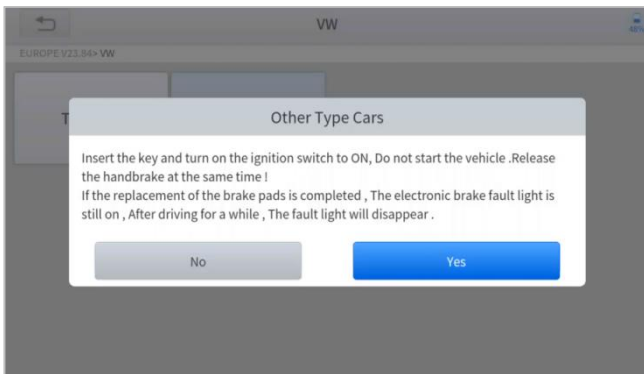

Figure 5-4 Sample of EPB function (screen 1)

3. Enter the **Enter maintenance mode** menu and release the handbrake brake. And press **OK** after completing the instructions shown.

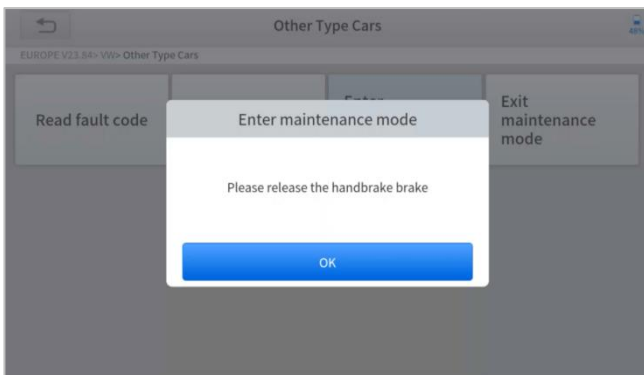

Figure 5-5 Sample of EPB function (screen 2)

4. Wait until the message of '**Successful operation**' pops up. And press **OK** to exit the menu.
5. Enter the **Exit maintenance mode** menu and wait until the message of "**Successful operation**' pops up.

## 5.3 SAS

Steering Angle Sensors (SAS) System Calibration permanently stores the current steering wheel position as the straight-ahead position in the SAS EEPROM. Therefore, the front wheels and the steering wheel must be set exactly to the straight-ahead position before calibration. In addition, the VIN is also read from the instrument cluster and stored permanently in the SAS EEPROM. On successful completion of calibration, the SAS fault codes will be automatically cleared.

To reset the steering angle, you need to first find the relative zero point position for the car to drive in a straight line. Taking this position as a reference, the ECU can calculate the accurate angle for left and right steering.

After replacing the steering angle position sensor, replacing steering mechanical parts (such as steering gearbox, steering column, end tie rod, steering knuckle), performing four-wheel alignment, or recovering the car body, you must reset the steering angle.

***The operation guidelines of the SAS function are shown below:***

1. Enter the **SAS** menu and choose relevant models according to the vehicle being tested.
2. Enter the **Set steering angle sensor** menu and follow the instructions displayed.

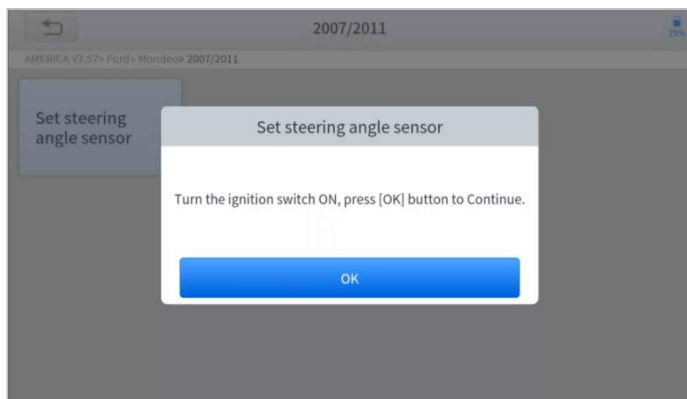

Figure 5-6 Sample of SAS function (screen 1)

3. Wait until the following instruction is displayed and press **Yes** after completing the instructions shown.

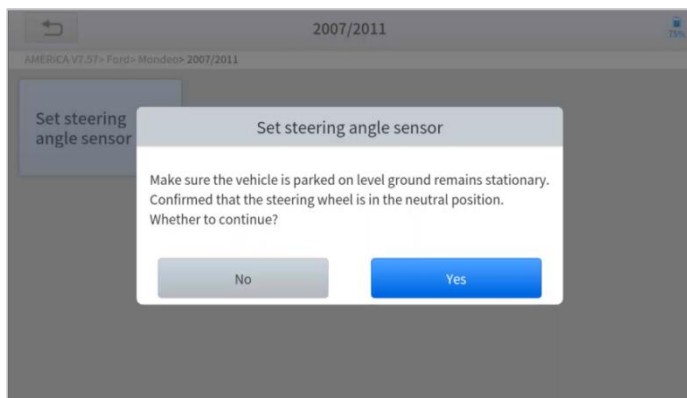
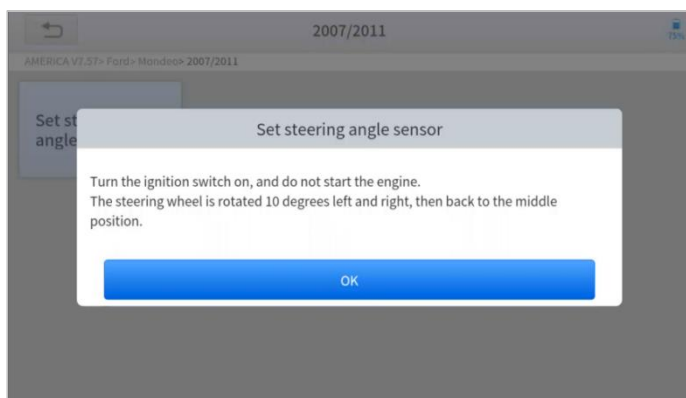

Figure 5-7 Sample of SAS function (screen 2)

Follow the instructions displayed and press **OK** after completing the instructions shown.



*Figure 5-8 Sample of SAS function (screen 3)*

4. Wait until the following instruction is displayed and press **OK** after completing the instructions shown.

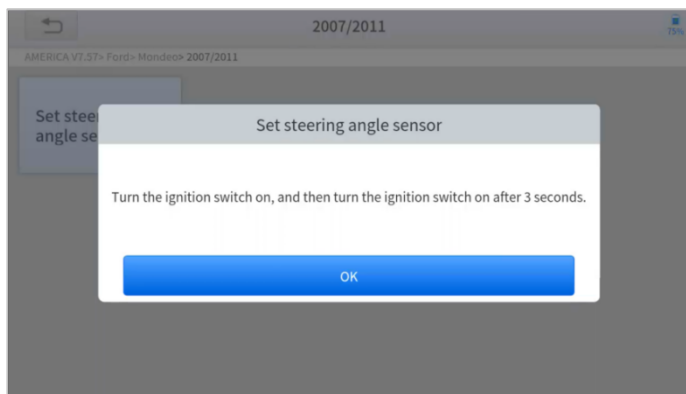

*Figure 5-9 Sample of SAS function (screen 4)*

5. Message of '**Function execution is completed**' displayed when the SAS function has been successfully performed.

## 5.4 DPF

The Diesel Particle Filter (DPF) function manages DPF regeneration, DPF component replacement teach-in, and DPF teach-in after replacing the engine control module (ECM).

The ECM monitors driving style and selects a suitable time to employ regeneration. Vehicles driven a lot at idling speed and low load will attempt to regenerate earlier than vehicles driven more with higher load and speed. For regeneration to take place, a prolonged high exhaust temperature must be obtained.

In the event of the car being driven in such ways that regeneration is not possible, i.e., frequent short journeys, a diagnostic trouble code will eventually be registered in addition to the DPF light and "Check Engine" indicators displaying. A service regeneration can be requested in the workshop using the diagnostic tool.

DPF regeneration is used to clear PM (Particulate Matter) from the DPF filter through continuous combustion oxidation mode (such as high-temperature heating combustion, fuel additive or catalyst to reduce PM ignition combustion) to stabilize the filter performance.

DPF regeneration may be performed in the following cases:

- The exhaust back pressure sensor is replaced.
- The PM trap is removed or replaced.
- The fuel additive nozzle is removed or replaced.
- The catalytic oxidizer is removed or replaced.
- The DPF regeneration MIL is on and maintenance is performed.
- The DPF regeneration control module is replaced.

***The operation guidelines of the DPF function are shown below:***

1. Enter the **DPF** menu and choose relevant models according to the vehicle being tested.
2. Enter the **DPF regeneration** menu.
3. Read carefully and complete the **requisites** listed before performing the DPF regeneration function. And press **OK** after completing the instructions shown.

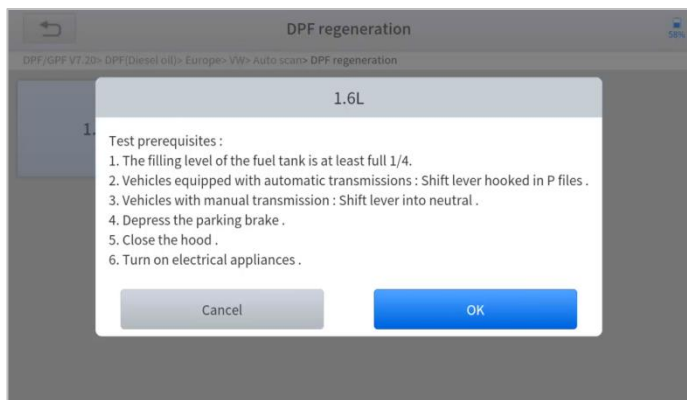

Figure 5-10 Sample of DPF function (screen 1)

4. Read the fuel tank level and make sure that it fulfils the requirement displayed.
5. Read the carbon deposit load.
6. Choose the drive to warm up and follow the instructions listed below. And press OK after completing the instructions shown.

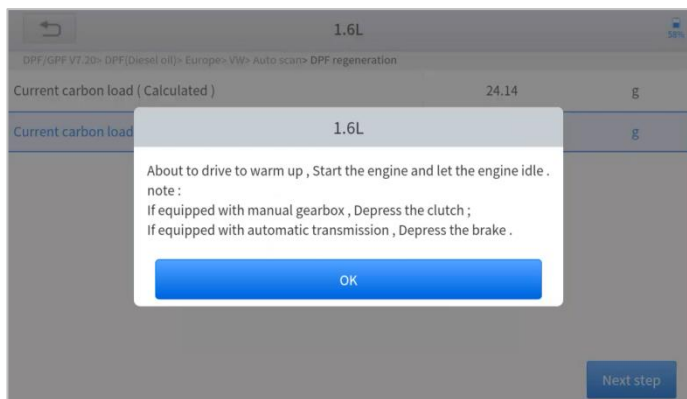

Figure 5-11 Sample of DPF function (screen 2)

7. Read the note carefully and follow the instructions shown on the

screen. And press OK after completing the instructions shown.

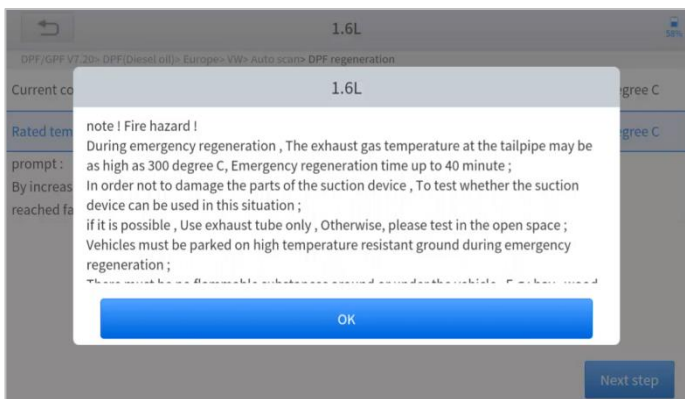

Figure 5-12 Sample of DPF function (screen 3)

8. Follow the instructions displayed and press **OK** after completing the instructions shown. Please pay attention to the Note.

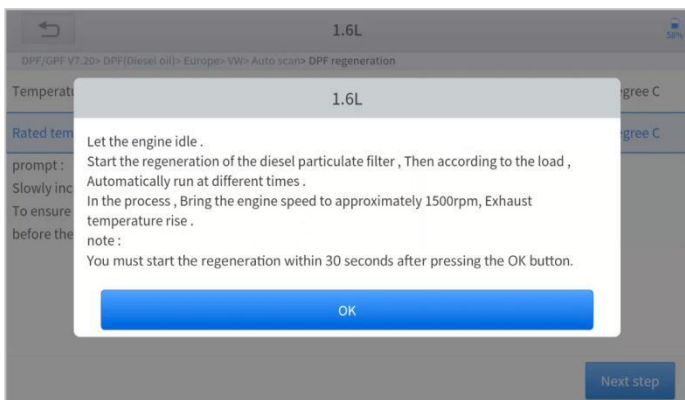

Figure 5-13 Sample of DPF function (screen 4)

9. Press the OK button to start the regeneration.

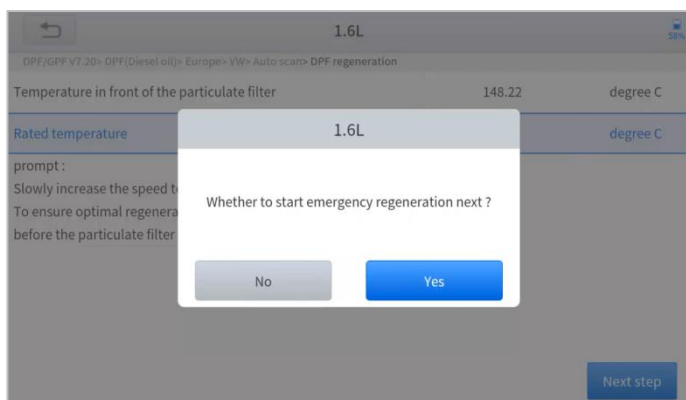

Figure 5-14 Sample of DPF function (screen 5)

10. Wait for the value of the carbon deposit to decrease until a message of 'Emergency regeneration has been completed' pops up, this process may take up to 40 minutes.

1.6L		
DPF/GPF V7.20> DPF(Diesel oil)> Europe> VW> Auto scan> DPF regeneration		
Regeneration duration	0.00	min
Carbon deposit	22.78	g
Rotating speed	781	rpm
Waste temperature upstream of turbocharger	143.41	degree C
Upstream of particulate filter	143.21	degree C
Downstream of particulate filter	112.38	degree C
Next step		

Figure 5-15 Sample of DPF function (screen 5)

11. Wait for 2 minutes to let the particulate filter cool down.



DPF/GPF V7.20> DPF(Diesel oil)> Europe> VW> Auto scan> DPF regeneration		
Current carbon load ( Calculated )	24.14	g
Current carbon load ( Measurements )	1.32	g
Let the engine run at idle again 2 Minutes to cool down the hot particulate filter	120	s

Figure 5-16 Sample of DPF function (screen 6)

12. Press drop out to exit the DPF function.

## 5.5 BMS RESET

The Battery Management System (BMS) allows the scan tool to evaluate the battery charge state, monitor the close-circuit current, register the battery replacement, and activate the rest state of the vehicle.

This function enables you to perform a resetting operation on the monitoring unit of the vehicle battery, in which the original low battery fault information will be cleared and battery matching will be done.

Battery matching must be performed in the following cases:

- The main battery is replaced. Battery matching must be performed to clear original low battery information and prevent the related control module from detecting false information. If the related control module detects false information, it will invalidate some electric auxiliary functions, such as automatic start & stop function, sunroof without one-key trigger function, and power window without automatic function.
- Battery matching is performed to re-match the control module and motoring sensor to detect battery power usage more accurately, which can avoid an error message displayed on the instrument cluster.

**The operation guidelines of the BMS Reset function are shown below:**

1. Enter the **BMS Reset** menu and choose relevant models according to the vehicle being tested.
2. Turn on the ignition switch.
3. Press **OK** to continue the BMS function.
4. Enter **battery capacity** (within the given range) and press **OK** after the input.



*Figure 5-17 Sample of BMS function (screen 1)*

5. Enter the battery manufacturer and press OK after the input.

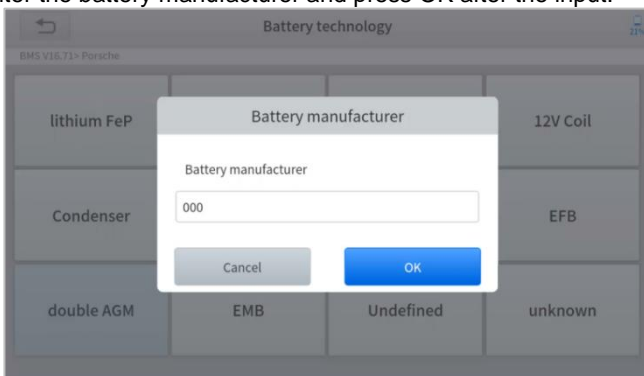

*Figure 5-18 Sample of BMS function (screen 2)*

6. Enter the 10-digit battery serial number and press OK after the input.



Figure 5-19 Sample of BMS function (screen 3)

## 5.6 THROTTLE

Throttle Position Sensor (TPS) Match, this function enables you to make initial settings to throttle actuators and returns the “learned” values stored on ECU to the default state. Doing so can accurately control the actions of regulating throttle (or idle engine) to adjust the amount of air intake.

***The operation guidelines of the Throttle function are shown as below:***

1. Enter the **Throttle** menu and choose relevant models according to the vehicle being tested.
2. Enter the **Auto Recognition** menu and turn on the ignition switch.
3. Read carefully and complete the **requisites** listed before performing the throttle regeneration function. And press **OK** after completing the instructions shown.

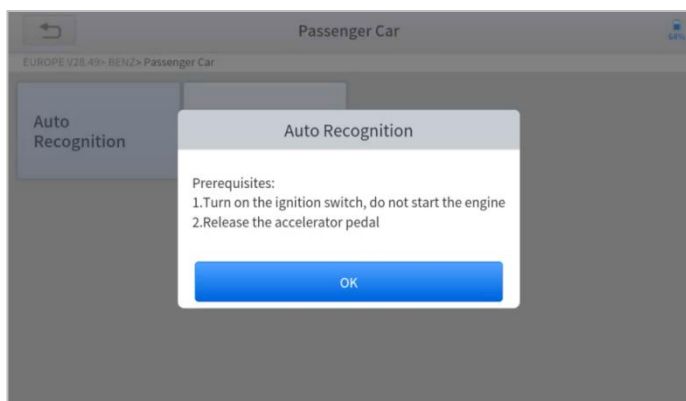

Figure 5-20 Sample of throttle function (screen 1)

4. Wait until all the parameters are read and displayed.

Auto Recognition		
EUROPE V28.49> BENZ> Passenger Car		
Engine speed(rpm)	0	<= 10
Coolant temperature(deg C)	48.00	5.00-100.00
Intake air temperature(deg C)	12.00	<= 40
Accelerator pedal position(%)	0.39	<= 5
Throttle regulator	Already learned	Status
F1:Exit F2:Match the throttle limit position		
		<input type="button" value="F1"/> <input type="button" value="F2"/>

Figure 5-21 Sample of throttle function (screen 2)

5. Press the **F2** button and wait until a message of '**Match successfully**' pops up.

## 5.7 INJECTOR CODING

This function can write the identification code of the fuel injector into the ECU so that the ECU can recognize and work normally. Write actual injector code or rewrite code in the ECU to the injector code of the corresponding cylinder for controlling accurately and correcting cylinder injection quantity.

After the ECU or injector is replaced, the injector code of each cylinder must be confirmed or re-coded so that the cylinder can better identify injectors to accurately control fuel injection.

① In general cases, there is no need to do the coding matching function after cleaning.

① The identification of the fuel injector includes its working accuracy value and type value. When replacing it, you need to find the corresponding model for replacement.

① At present, mainstream cars support injector coding functions.

**The operation guidelines of the Injector Coding function are shown as below:**

1. Enter the **Injector coding** menu and choose relevant chassis models according to the vehicle being tested.
2. Enter the **Fuel injection nozzle injection volume adjustment** menu.
3. Read the note displayed carefully and press **OK** after the reading.

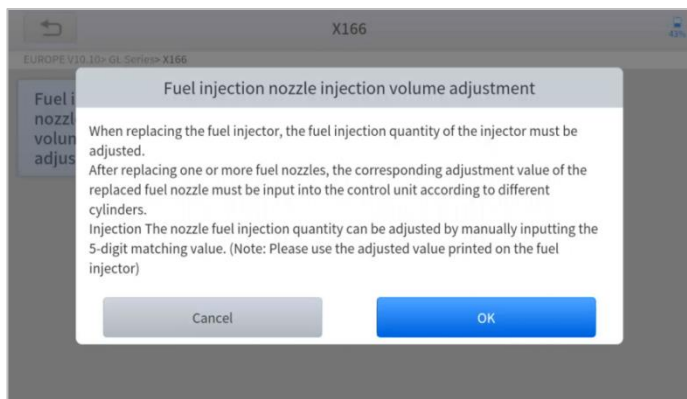

Figure 5-22 Sample of injector coding function (screen 1)

4. Read and confirm the value stored in the cylinders.

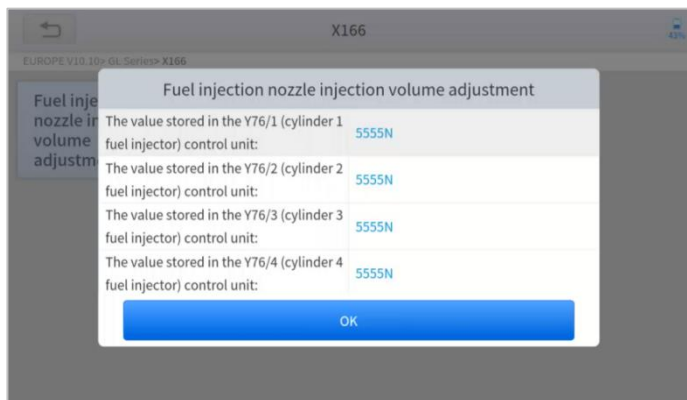

Figure 5-23 Sample of injector coding function (screen 2)

5. Enter the Change the value of cylinder menu of the replaced injector(s), enter the new 5-digit value, and then press **OK**.

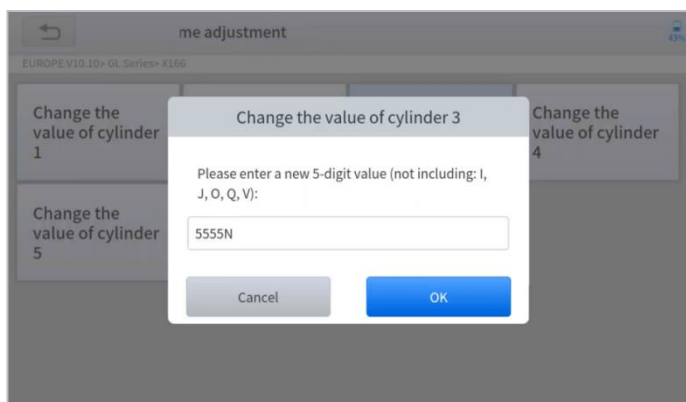

Figure 5-24 Sample of injector coding function (screen 3)

6. Wait until the message **'Write successfully' pops up.**
7. Turn off the ignition switch.
8. Wait until the message asked you to turn on the ignition switch.
9. Re-enter the Fuel injection nozzle injection volume adjustment menu to check whether the new value(s) are shown.

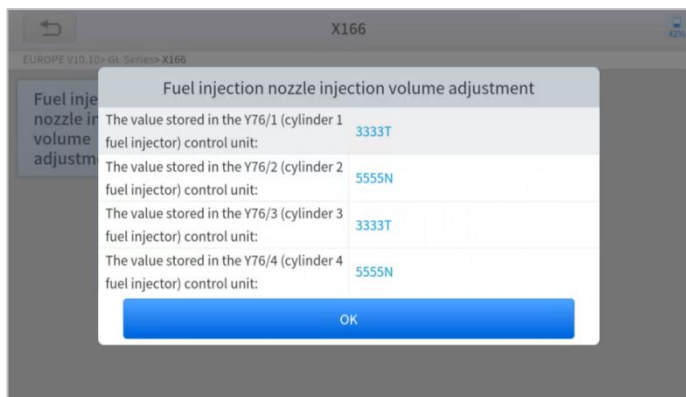

Figure 5-25 Sample of injector coding function (screen 4)

## 5.8 GEARBOX MATCH

After changing the gearbox or changing the gearbox ECU, you need to use the gearbox matching function to re-match the engine and the gearbox.

ⓘ Before resetting the gearbox, please check the gearbox control unit to ensure that there is no fault code. If there is a fault code, the gearbox memory function cannot be reset. Please road test after reset.

**The operation guidelines of the Gearbox Matching function are shown as below:**

1. Enter the **Gearbox matching** menu and choose relevant models according to the vehicle being tested.
2. Enter the **Reset adaptive value** menu.
3. Turn on the ignition without starting the engine.
4. Read the note and press **OK** to continue the Gearbox Matching function.

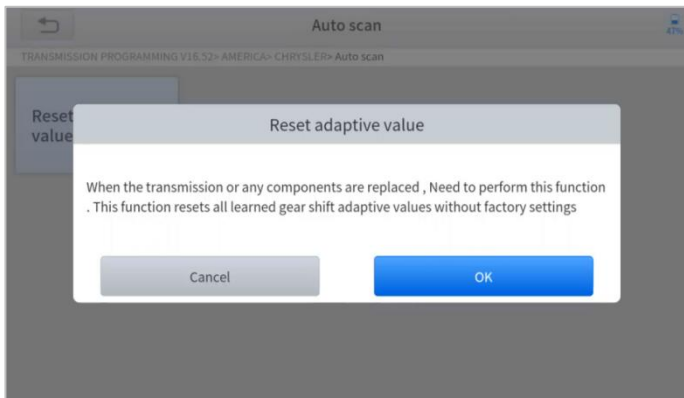

Figure 5-26 Sample of gearbox matching function (screen 1)

5. Wait until the message 'Successful operation' pops up.

## 5.9 GEAR LEARNING

The crankshaft position sensor learns crankshaft tooth machining tolerance and saves to the tablet to more accurately diagnose engine misfires. If gear



learning is not performed for a car equipped with a Delphi engine, the MIL turns on after the engine is started. The diagnostic device detects the DTC P1336 'Gear not learned'. In this case, you must use the diagnostic device to perform gear learning for the car. After gear learning is successful, the MIL turns off. This function can complete the self-learning of the gearbox and improve the quality of shifting.

After the engine ECU, crankshaft position sensor, or crankshaft flywheel is replaced, or the DTC 'gear not learned' is present, gear learning must be performed.

**The operation guidelines of the Gear learning function are shown as below:**

1. Enter the **Gear learning** menu and choose relevant models according to the vehicle being tested.
2. Turn on the ignition switch to start the vehicle.
3. Enter the **Tooth Learning** menu.
4. Read carefully and complete the **requisites** listed before performing the gear learning function. And press **OK** after completing the instructions shown

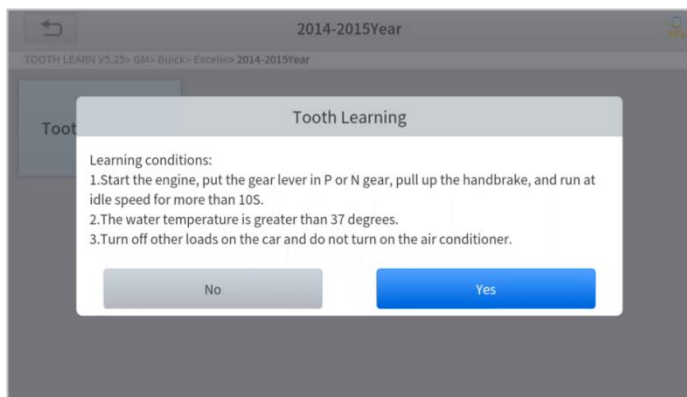

Figure 5-27 Sample of gear learning function (screen 1)

5. Read the instructions displayed and press Yes to start the learning process.

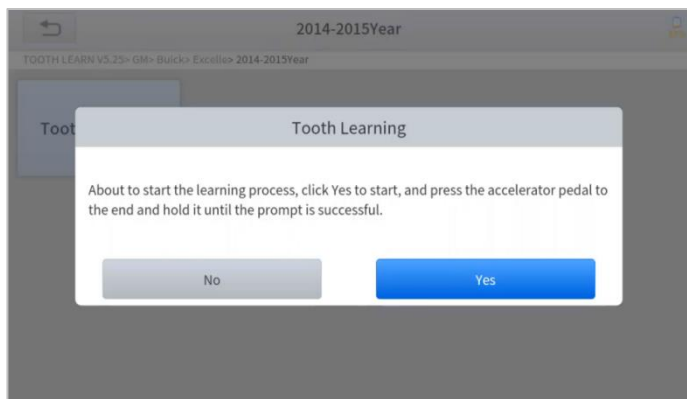

Figure 5-28 Sample of gear learning function (screen 2)

6. Press the accelerator pedal down and hold it until a message of 'The learning is successful, please release the accelerator pedal.' pops up.
7. Release the accelerator pedal and press OK to exit the gear learning function.

## 6. REPORT

Diagnostic Report is used for viewing and printing the saved files, such as Live Data, Trouble codes or pictures generated in the process of diagnosis, users also can view a record of which cars have been previously tested. It includes 3 parts:

- **Report**
- **Replay**
- **File Management**

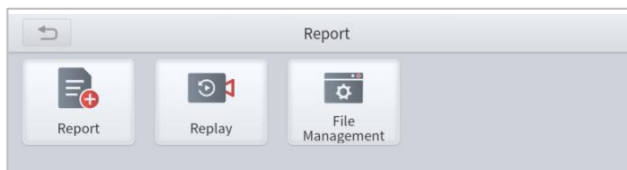

Figure 6-1 Sample of Report

## 6.1. REPORT

This feature provides a history of diagnostic reports, where you can view and delete the vehicle's diagnostic reports according to your needs.



Report	
GM 2021-05-15 10:59:36	Delete
日产 2021-05-12 16:18:37	Delete
DEMO 2021-05-12 14:31:24	Delete

Figure 6-2 Sample of Report List

When you open the report, located in the header of the table is the studio information you filled in advance in the system setup, then the information of the vehicle, including the diagnosis date and time, VIN, vehicle brand, diagnosis path, etc., as shown as below:

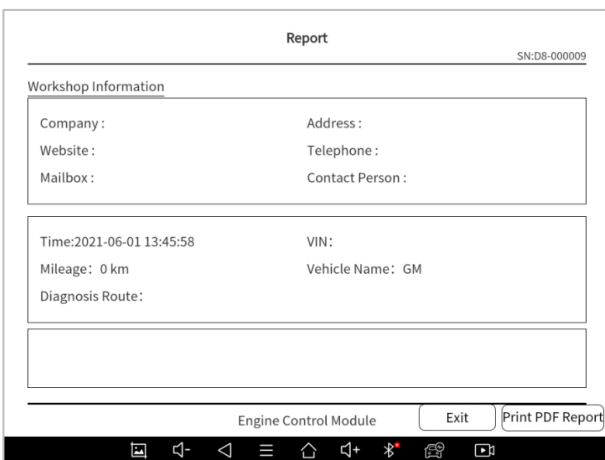

Report SN:D8-000009

---

Workshop Information

Company :	Address :
Website :	Telephone :
Mailbox :	Contact Person :

Time:2021-06-01 13:45:58	VIN:
Mileage: 0 km	Vehicle Name: GM
Diagnosis Route:	

Engine Control Module Exit Print PDF Report

Figure 6-3 Sample of Report

## ■ Print PDF Report

As you can see, you also could click " **Print PDF Report** " at the bottom right corner to output the pdf report. If you need to close the report, you could tap on the button "Exit".

Please follow the below steps to print your report ▼

Step 1: Install an APP that can drive your target printer. Add the printer and input the IP address of the printer in the APP, or you can contact your dealer for help.

Step 2: Back to the Android main menu, go to Settings -> Printing-> Turn printer on.

Step 3: Report-> Choose report-> Print PDF Report-> Print

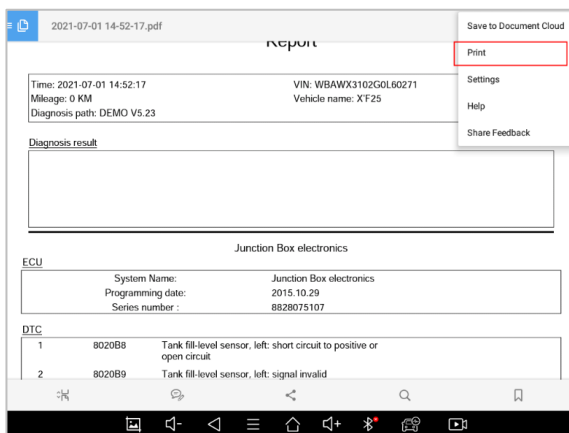

Figure 6-4 Sample of How to Print Report, Screen 1

Step 4: Click the top-left corner of the screen and choose the printer you added before. Then click the button on the right to print.



Figure 6-5 Sample of Report, Screen 2

## 6.2. REPLAY

This function allows you to replay the living data recorded during the diagnosis process.



Figure 6-6 Sample of Data Playback, Screen 1

Before replaying the living data, please make sure you click on the "Save to Reference" button during the diagnosis

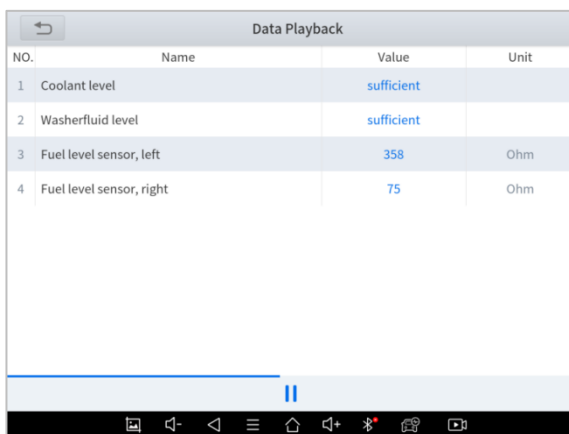

Figure 6-7 Sample of Data Playback, Screen 2

## 6.3. FILE MANAGER

This function allows you to check and delete files on the device. Please use this function under the guidance of professionals. Ordinary users are not recommended to use it by themselves!

# 7. SETTINGS

Click the Settings button to adjust the default settings and view information about the H6 ELITE Smart Diagnostics System. There are seven options available in the system settings:

- **Language**
- **Units**
- **My Workshop Info**
- **VCI Info**
- **About**

## 7.1. LANGUAGE

The languages supported by this device are listed in **Settings**. In areas outside the English area, the default language is English and the local official language.

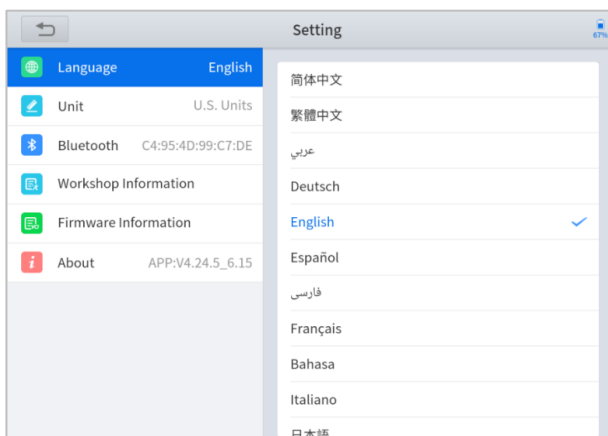

Figure 7-1 Sample of Language Selection

Users can switch between English and local official languages on the device by themselves. If you need to switch other languages, please contact the dealer to unbind the current language configuration and rebind it to the

language configuration you need to switch. After the configuration is successfully changed, you can switch the target language.

### Please follow the steps below to switch languages

Step1: Contact your dealer and leave a message about the language you need and the S/N of your device

Step2: **Settings->Language->**Choose language

Step3: **OS Settings->Language & input->**Choose Language

Step4: Back to **Upgrade**

NOTE: Please be sure to download the model software again after switching the language, otherwise the diagnosis menu will be blank

## 7.2. UNITS

You can switch the unit used by the system. H6 ELITE Smart Diagnostics System provides you with **metric** and **imperial** units. You can directly click on the unit when you need it, after the switch is successful, a blue checkmark will be shown behind the unit's name.

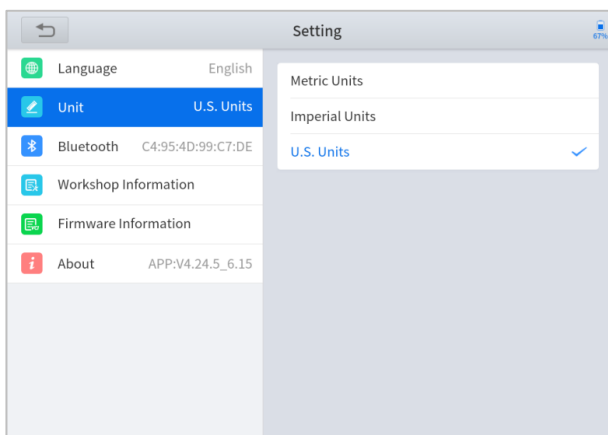
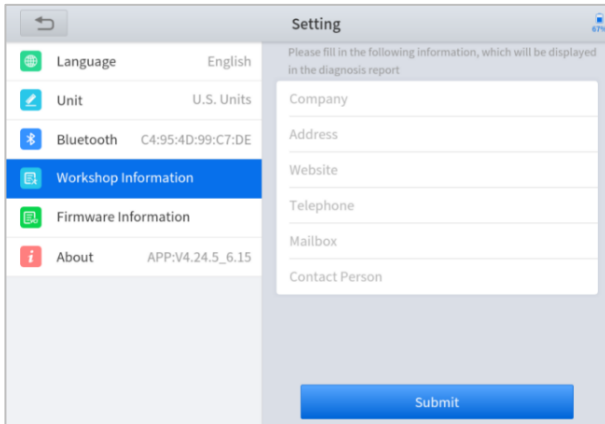

Figure 7-2 Sample of Units Selection

### 7.3. MY WORKSHOP INFO

Click on **My Workshop Information**, you can input your workshop information here. As shown in the figure below, you just need to fill in the valid information in the corresponding column and click "**SUBMIT**". And then it will show your workshop information in the report when you generate a diagnostic report, including your company name, address, website, telephone, and mailbox.



*Figure 7-3 Sample of Workshop Information*

### 7.4. FIRMWARE INFORMATION

You can view the firmware information here, including the firmware name, the latest firmware version, the currently used firmware version, and the firmware type.



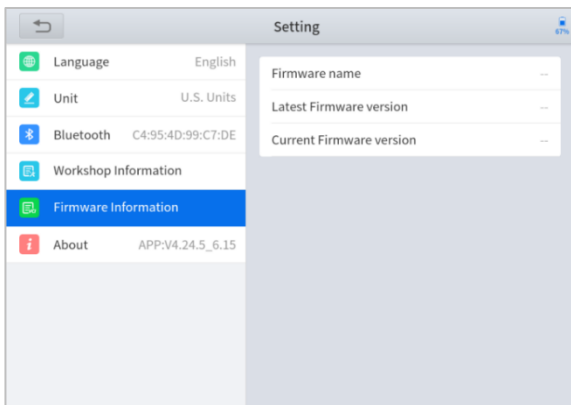

Figure 7-4 Sample of Firmware Information

NOTE: To view the firmware information, you need to enter the diagnostic package first to get it works.

## 7.5. ABOUT

Tap on **ABOUT**, you can check the serial number and APP version on here.

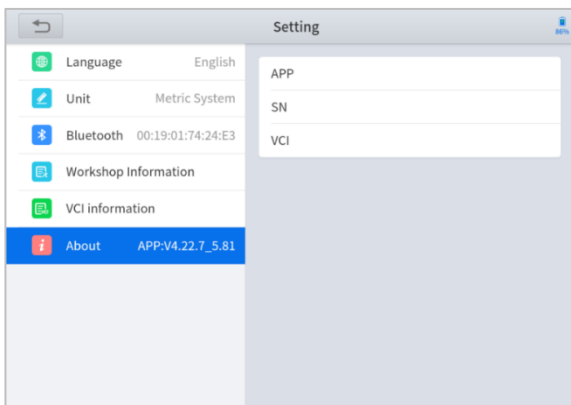

Figure 7-5 Sample of About Information

## 8. FACTORY RESET

After first-time users turn on the system, the system will automatically enter the guide process and request the user to select the system operating language.



Figure 8-1 Sample of Selecting Languages

After selecting the system language, click **Next** to enter the Wi-Fi connection page, as shown below:

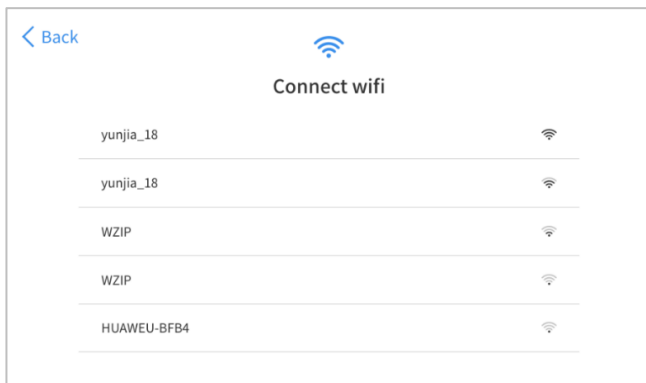
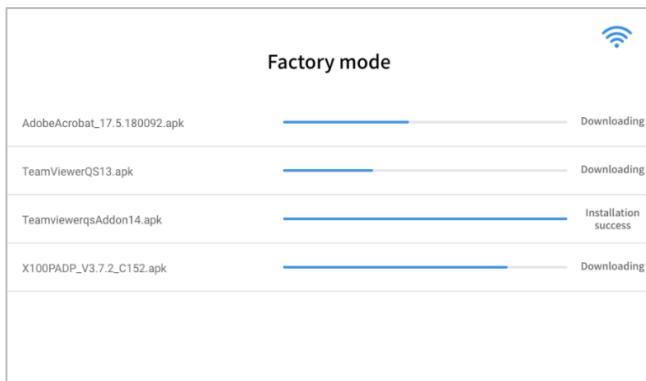

Figure 8-2 Sample of Selecting Wi-Fi

Select a network to connect to on the Wi-Fi connection page.

After successful network connection, the automatic system will jump to **Factory mode** to download the software:



*Figure 8-3 Sample of Factory Mode*

Once the software has been downloaded, the tablet will automatically reboot and request the system language selection again.



*Figure 8-4 Sample of Selecting Languages, Screen2*

After setting the system language, you will enter the activation page, as shown in the figure below. You can also click the "Trial" button in the upper right corner to try it out before activation.

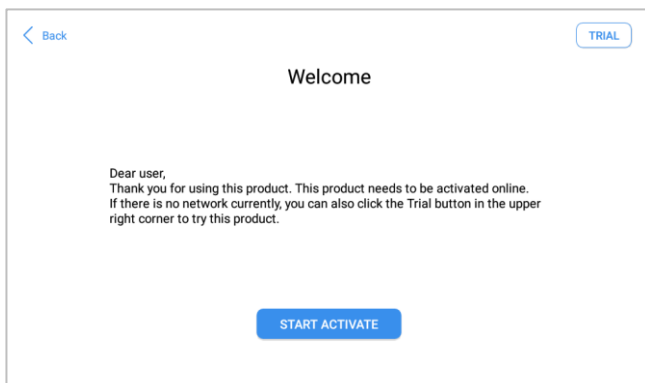

Figure 8-5 Sample of Activation, Screen 1

Click **Start Activate** to enter the activation page, as shown below:

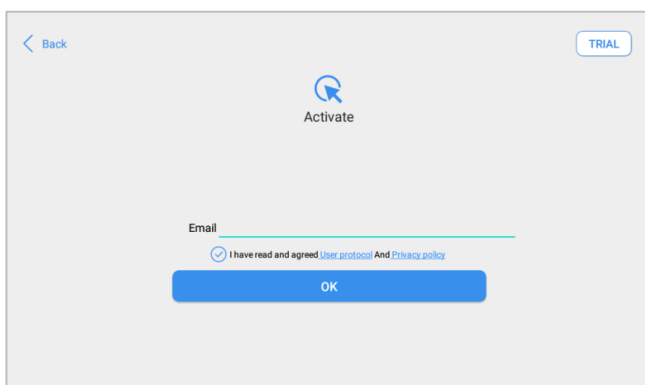
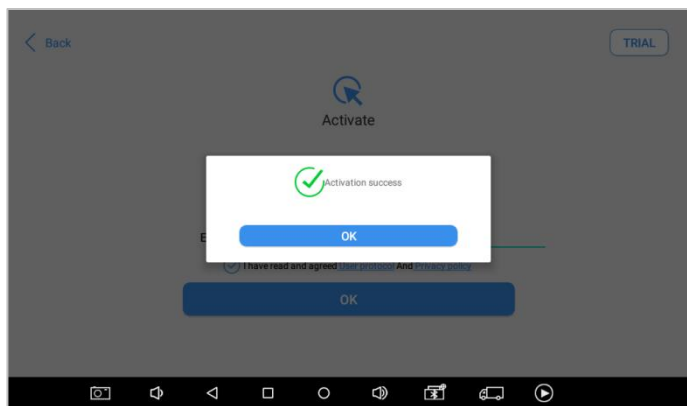

Figure 8-6 Sample of Activation, Screen 2

A pop-up window showing **Activation Success** indicates that you have completed the first boot setup, click **OK** to enter the diagnostic system and start using the device.



*Figure 8-7 Sample of Activation, Screen 3*

## 9. REMOTE ASSISTANCE

Tap on "**Remote**" to start the TeamViewer quick support program, which is a simple, fast, and secure remote-control screen. You can use this application to enable them to control your tablet on a PC through the TeamViewer software, thereby obtaining temporary remote support from Xtool's technical support centre.

Tablets and mobile devices running TeamViewer are identified by a globally unique ID. When the remote application is started for the first time, the ID will be automatically generated according to the hardware characteristics and will not be changed in the future. This TeamViewer ID can individually access all TeamViewer clients.

Before launching the remote desktop application, make sure that the tablet is connected to the Internet so that you can access the tablet to receive remote support from a third party. If you encounter problems and are not able to solve them, you could open this application and ask for remote assistance.

To obtain remote support from your partners or Xtool After-service Center:

1. Turn on the power of the tablet.

2. Click **Remote** in the diagnosis application. The TeamViewer screen is displayed, and the device ID will be generated.
3. Your partner must install the remote-control software on his/her tablet by downloading the full version of the TeamViewer program (<http://www.teamviewer.com>) online, and then start the software on his/her tablet at the same time, to provide support and remote control of the tablet.
4. Provide your ID to the partner or Xtool technician, and then wait for him/her to send you a remote-control request.
5. A pop-up window will be shown asking you to confirm to allow the remote-control program to control your device.
6. Click **Allow** to accept, or click **Reject** to reject.

**i** Please contact Xtooltech's technical team in advance to book a remote time and provide your Team Viewer ID ([supporting@xtooltech.com](mailto:supporting@xtooltech.com)).

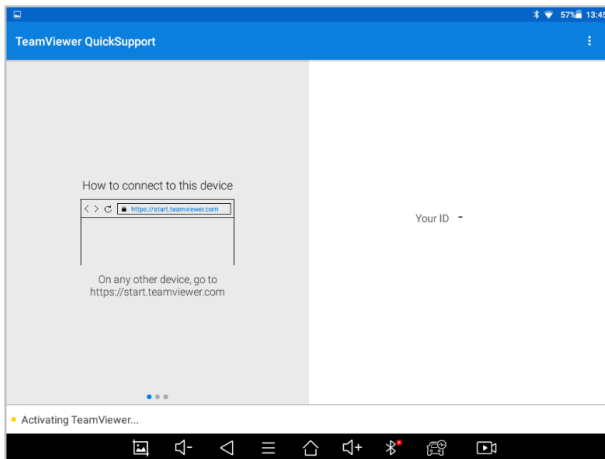

*Figure 9-1 Sample of Activating Team Viewer, Screen 1*

# 10. FAQ

## Q1: FAILED TO GENERATE DIAGNOSIS REPORT

1. Currently only perform diagnostic functions, that is, read ECU information, read code and clear code, live data, freeze frame, which can trigger a diagnostic report. Other functions, such as immobilization and maintenance services will not be displayed in the report.
2. After entering the diagnosis menu, you need to perform one specific function before the system can generate a diagnosis report normally. After the diagnosis is completed, you need to step back to the previous menu step by step to generate the diagnosis report successfully. If the APP is killed directly, the report also cannot be triggered.
3. If the report still cannot be generated after troubleshooting according to the above prompts, please try to exit the APP, enter the system settings, and then choose to clear the APP cache.

Enter the path: Setting>>Apps>>Diagnosis>>Clear Cache

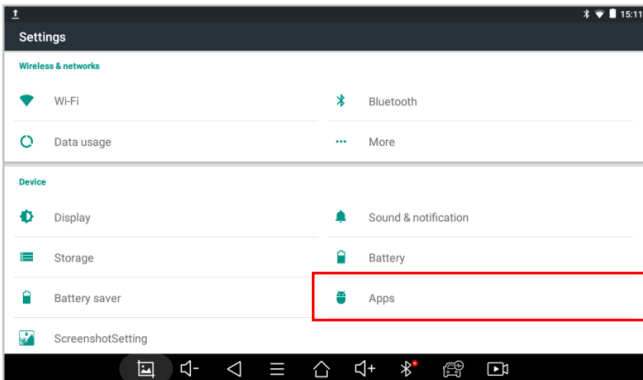

Fig 10-1 Sample1: How to clear APP cache

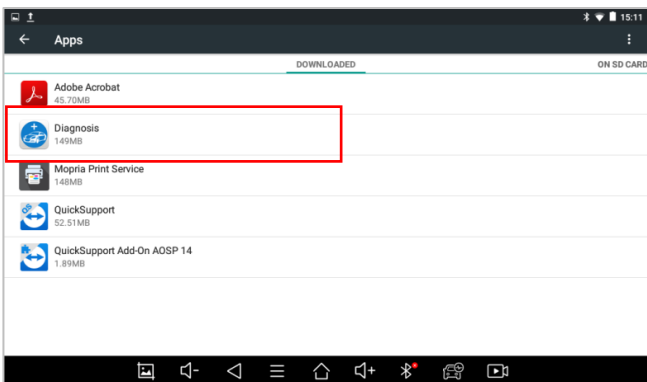

Fig 10-2 Sample1: How to clear APP cache

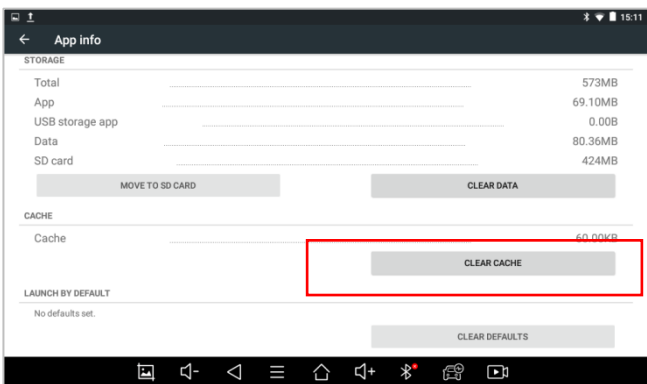

Fig 10-3 Sample1: How to clear APP cache

## Q2: HOW TO PRINT DIAGNOSIS REPORT

The XTOOL device is compatible with third-party print drivers. You can download the printer driver you need in the browser that comes with the tablet to install it, and then set your printer in the OS settings. After the setting is completed, you can print it in the **Report**.



### **Q3: FAILED TO EXTRACT FILES**

Since the XTOOL tablet is equipped with an Android system, you have to confirm the system type of receiver.

**For Android:** supports transferring files via Bluetooth, USB cable, etc.;

**For IOS:** only supports transferring files through a wired connection (Bluetooth connection is not available).

### **Q4: MAILBOX SUPPORTED**

The diagnosis tablet supports various mailboxes, including Hotmail, Outlook, Yahoo, Gmail, etc. When you set up the email, please make sure that the email client configuration address you entered is correct.

Due to the adjustment of Google's security policy, starting from May 31, 2022, the Android system of this device will no longer support the email client to log in to the Gmail account. To use the Gmail mailbox service, please log in to the web version of Gmail using a browser.

### **Q5: HOW TO MAKE AN APPOINTMENT FOR REMOTE SUPPORT**

Please contact your dealer, or send an email to our technical support center. (Email address: [supporting@xtooltech.com](mailto:supporting@xtooltech.com)) And our technical support team will confirm the time of remote support with you.

### **Q6: HOW TO GENERATE AND UPLOAD DIAGNOSTIC LOG FILES**

The A80 tablet will automatically generate and store the diagnostic logs. When the device is connected to the Internet, it will automatically upload all the stored diagnostic logs to the backend system.

### **Q7: HOW TO SWITCH LANGUAGES**

1. Contact your dealer and leave a message about the language you need and the S/N of your device, The technician will modify the language configuration for you in the backend system.

2. **Settings->Language->**Choose language
3. Back to **Updates** to update all the software again

#### **Q8: FAILED TO DIAGNOSE VEHICLE**

1. Contact your dealer to confirm whether the vehicle model is supported by the scan tool you owned.
2. Check whether the vehicle is properly connected (e.g. whether the ignition is ON, and the diagnosis of some vehicles need to turn on the engine), If your tablet is equipped with a VCI box, please check the status of the VCI box indicator.
3. Confirm whether you have entered the correct diagnosis menu.
4. Confirm whether the **AUTO-SCAN** function can assist you to enter the correct diagnosis menu, or whether the **OBDII** function works.
5. Check whether the software is the latest version, if not, please update to the latest version first.

#### **Q9: FAILED TO ACTIVATE OR REGISTER**

- For 'Activation Failed'

Generally caused by network instability, please switch to a more stable network and try to activate again.

- For 'Registration Failed'

Generally, it is caused by the connection timeout or the sending timeout, please check whether you have blocked the outgoing network traffic to non-US regions like China. We recommend that you unblock and try to register again.

## Q10: FAILED TO TURN ON WHEN CHARGING

In the charging state, you need to first press the power button to light up the screen (showing the charging status). Then press and hold the power button for 4-5 seconds until the boot animation is shown on screen.

## Q11: FAILED TO OPEN THE DIAGNOSIS APP

“With PROMPT ‘Sync your device. the device has been offline for more than 30 days. you should connect INTERNET SYNC DEVICES TO THE NETWORK STATUS!’”

The tablet has to connect to the network every 30 days, otherwise, the diagnosis app will be locked and disabled until the device is connected to the network. If you have ruled out the network problem and ensured that the device can be connected to the Internet normally, and your device still cannot use the diagnostic function, please contact our technical team (supporting@xtooltech.com)

## Q12: FAILED TO ENTER VEHICLE MENU

If you encounter the following two prompts, please delete the package and download it again to diagnose

- ‘Failed’

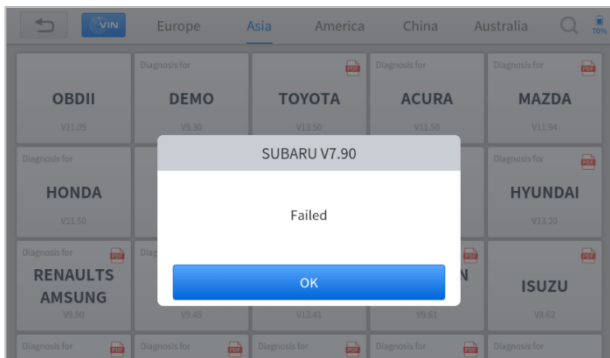

- 'License exception'

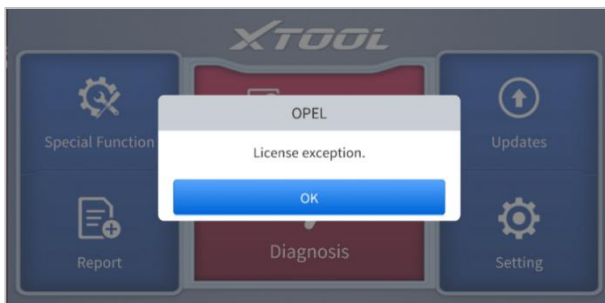

## 11. WARRANTY & SERVICES

Shenzhen Xtooltech Intelligent Co., LTD.(the Company) warrants to the original retail purchaser of this XTOOL device that should this product or any part thereof during normal usage and under normal conditions be proven defective in material or workmanship that results in product failure within one year from the date of purchase, such defect(s) will be repaired, or replaced (with new or rebuilt parts) with Proof of Purchase, at the Company's option, without charge for parts or labor directly related to the defect(s).

The Company shall not be liable for any incidental or consequential damages arising from the use, misuse, or mounting of the device.

This warranty does not apply to:

- 1.Products subjected to abnormal use or conditions, accident, mishandling, neglect, unauthorized alteration, misuse, improper installation/repair or, improper storage;
- 2.Products whose mechanical serial number or electronic serial number has been removed, altered, or defaced;
- 3.Damage from exposure to excessive temperature or extreme environmental conditions;

4.Damage resulting from connection to, or use of any accessory or other product not approved or authorized by the Company;

5.Defects in appearance, cosmetic, decorative, or structural items such as framing and non-operating parts;

6.Products damaged from external causes such as fire, dirt, sand, battery leakage, blown fuse, theft, or improper usage of any electrical source.

## **SHENZHEN XTOOLTECH INTELLIGENT CO., LTD**

Company address: 17&18/F, Building A2, Creativity City, Liuxian  
Avenue, Nanshan District, Shenzhen, China

Factory address: 2/F, Building 12, Tangtou Third Industrial Zone,  
Shiyan Street, Baoan District, Shenzhen, China

Service-Hotline: 0086-755-21670995/86267858

Email: [marketing@Xtooltech.com](mailto:marketing@Xtooltech.com)

Fax: 0755-83461644

Website: [www.Xtooltech.com](http://www.Xtooltech.com)